

INSTRUCTION MANUAL

T154 WS ED25

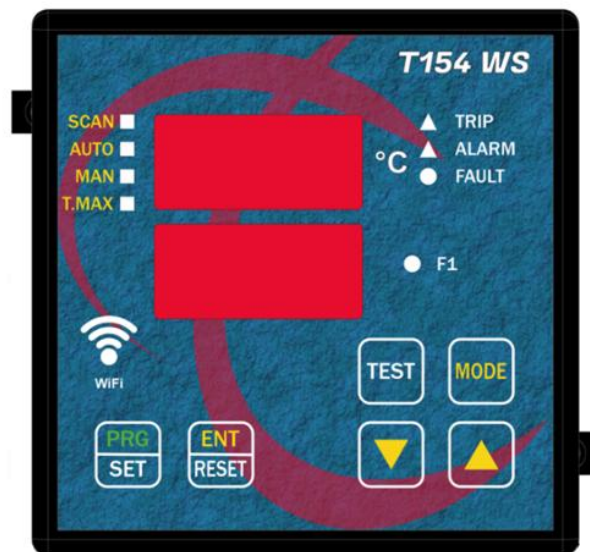

1MN0282 REV. 0



operates with ISO9001 certified quality system

TECSYSTEM S.r.l.
20094 Corsico (MI)
Tel.: +39-024581861

<http://www.tecssystem.it>

R. 1.1 04/02/26

ENGLISH

“Translations of the original instructions”

INTRODUCTION

First of all we wish to thank you for choosing to use a **TECSYSTEM** product and we strongly suggest that you read this instruction manual carefully: You will understand the use of the equipment and therefore be able to take advantage of all its functions.

ATTENTION! THIS MANUAL IS VALID AND COMPLETE FOR THE T154 WS ED25 MODEL CONTROL UNIT

TABLE OF CONTENTS

	PAGE
1) SAFETY REQUIREMENTS	4
2) ACCESSORIES	5
3) TECHNICAL SPECIFICATIONS	6
4) FRONT PANEL	8
• DISPLAY	9
• OPERATING PROGRAM CONTROL	—
• NOTES ON SCAN AND MAN FUNCTIONS	—
• LED TEST	—
• ALARM RELAY TEST	—
• ALARM RELAY SILENCING	—
• WIFI NETWORK ACTIVATION	10
5) ASSEMBLY	—
6) ELECTRICAL CONNECTIONS	11
• REAR T154 WS	—
• POWER SUPPLY	12
• ALARMS AND VENTILATION	—
• FAULT AND RESET MESSAGE SEQUENCE	—
7) PROGRAMMING	13
• T154 WS ED25	—
• PROGRAMMING NOTES	14
• TEMPERATURE SENSORS	15
• MEASUREMENT SIGNAL TRANSFER	—
• TEMPERATURE SENSOR DIAGNOSTICS	16
• VOTING FUNCTION	—
• PROGRAMMED DATA DIAGNOSTICS	—
• TEMPERATURE DIAGNOSTICS	17
• COOLING FAN CONTROL	—
• FAN TEST	—

	PAGE
8) FAILSAFE FUNCTION	18
9) Pt100 EXTENSION CABLE TECHNICAL SPECIFICATIONS	—
10) FCD FUNCTION	19
11) T154 WS WI-FI CONNECTION	—
• ACCESS POINT RESET MODE	20
12) TECSYSTEM WEB SERVER	21
• HOME SCREEN	22
• TEMPERATURE AND ALARMS SCREEN	—
• SETTINGS SCREEN	23
• NETWORK SETTINGS	24
• OPTIONS	25
• GRAPHICS SCREEN	26
• EVENTS SCREEN	27
• GRAPH DISPLAY NOTES	28
• CSV FILE EXPORT NOTES	—
• PIN CODE	—
13) TROUBLESHOOTING	29
14) WARRANTY REGULATIONS	—
15) EQUIPMENT DISPOSAL	30
16) USEFUL CONTACTS	—
17) FIRMWARE VERSION C01 T154-V WS	—
18) UL SPECIFICATION AND RATINGS	31

SAFETY REGULATIONS



ATTENTION:

Read the manual carefully before starting to use the control unit. Keep the instructions for future reference.



Do not open the device, touching any internal components can cause electric shock. Contact with a voltage over 50 Volts can be fatal. To reduce the risk of electric shock, do not dismantle the back of the device for any reason. Moreover its opening would void the warranty.

Before connecting the device to the power supply, make sure that all the connections are correct. Always disconnect the unit from the supply before any cabling modification.



Any work on the equipment must be entrusted to a qualified engineer.

Failure to comply with these instructions can cause damages, fires or electric shock, and possible serious injuries!

POWER SUPPLY

The T154 WS control unit can be supplied by 24 to 240 Vac-Vdc, irrespectively of polarity in Vdc. Before using it, make sure the power cable is not damaged, knotted or pinched. Do not tamper with the power cable. Never disconnect the unit by pulling the cable, avoid touching the pins. Do not carry out any operations of connecting/disconnecting with wet hands. To disconnect the device, do not use objects such as levers. Disconnect the power supply immediately if you notice that the device gives off a burning smell or smoke: contact the assistance.

LIQUIDS

Do not expose the equipment to splashes or drops, do not position it in places with humidity exceeding 90% and never touch with wet or damp hands. If any liquid penetrates the control unit, disconnect it immediately and contact technical service.

CLEANING

Disconnect the power cable before cleaning the control unit, use a dry cloth to dust it, without any solvent or detergents, and compressed air.

OBJECTS

Never insert any objects into the cracks of the control unit. If this happens, disconnect the control unit and contact an engineer.

USE RESERVED TO QUALIFIED PERSONNEL

The purchased goods are a sophisticated electronic device that is totally unsuitable to be used by non-qualified personnel. Any work must be carried out by a specialist engineer.

ACCESSORIES

The use of non-original accessories or spare parts can damage the unit and endanger user's safety. In the event of faults, contact technical service.

POSITIONING

Install the control unit indoors, in a place protected from water splashes and from the sun's rays. Do not place near heat sources exceeding the parameters stated in this manual. Position on a stable surface, far from any possible vibrations. Position the unit as far as possible from any intense magnetic fields.

REPAIRS

Do not open the control unit. For any fault, always use qualified personnel. The opening of the control unit and/or the removal of the series identifying label entails the automatic forfeiture of the warranty. The Warranty seal is applied to all devices, any attempt to open the unit would break the seal and cause the consequent automatic forfeiture of the warranty.

BATTERY

Inside the T154 WS device there is a lithium manganese dioxide battery. Do not open the control unit. The battery used is maintenance-free. Do not expose the device to temperatures above or below the operating range (-20°C to + 60°C) and do not expose it to fire (risk of explosion). In case of liquid leakage from the product and possible contact with the person (hands, eyes or other) or inhalation, contact your doctor immediately.

FUNCTIONS

To control the transformer correctly from a temperature point of view, enabling the VOTING function is allowed where the load distributed between the phases of the transformer is adequately balanced.

TECHNICAL INFORMATION OR REPORTING INFORMATION

Mail: support@tecsystem.it - tel: 02/4581861

ACCESSORIES

The following objects are present inside the box:

Control unit



Start guide and QR code



2 blocks for panel fixing
Screws tightening torque 0.29Nm

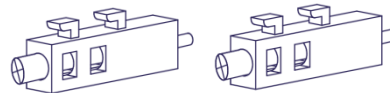

1 Terminal 3 pitch poles 5 supply
Code: 2PL0367 - Screws tightening torque 0.5Nm



1 relay terminal 10 poles pitch 5
Code: 2PL0394 - Screws tightening torque 0.5Nm



1 Terminal 12 poles pitch 3.81 sensors Pt100
Code: 2PL0420 - Screw tightening torque 0.25Nm



ATTENTION: always install the device using the terminals included in the pack.
The use of terminals other than those included with the control unit might cause malfunctions.

TECHNICAL SPECIFICATIONS	T154 WS ED25
POWER SUPPLY	
Supply rated values	24-240 Vac-Vdc 50/60HZ
Vdc with invertible polarities	•
INPUTS	
4 inputs for three-wire Pt100 RTD sensors (max section 1.5mm ²)	•
Connections on removable terminal boards	•
Input channels protected against electromagnetic interference	•
Thermoresistances cable compensations	500m (1mm ²)
OUTPUTS	
2 alarm relays (ALARM AND TRIP) SPDT	•
1 sensor or operating failure (FAULT) relay SPST	•
1 ventilation management relay FAN 1 SPST	•
Output relays with 10A-250Vca-res COS Φ =1 contacts	•
Wi-Fi Connection: frequency 2.4 GHz, protocol 802.11 b/g/n (HT20), WiFi frequency 2402-2480MHZ.	•
DIMENSIONS	
100 x 100 mm DIN 43700 prof. 131 mm	Hole 92 x 92 mm
TESTS AND PERFORMANCE	
Construction in compliance with the CE - RED regulations	•
Protection from electrical interference EN 61000-4-4	•
Dielectric strength 1500 Vac for a min. between output relays and sensors, relays and power supply, power supply and sensors	•
Accuracy $\pm 1\%$ full scale value, ± 1 digit	•
Ambient operating temperature from -20°C to $+60^{\circ}\text{C}$	•
Humidity 90% non-condensing	•
Polycarbonate frontal film IP65	•
Housing UL 94V-0	•
Absorption 7.5VA	•

TECHNICAL SPECIFICATIONS	T154 WS ED25
Digital linearity of sensor signal	•
Self-diagnostic circuit	•
Protection treatment of the electronic part	Optional
Internal battery for RTC power supply	3V 220mAh
DISPLAY AND DATA MANAGEMENT	
2 x 13 mm displays with 3 digits to display temperatures, messages and channels	•
3 LEDs to display the state of the alarms of the selected channel (ALARM-TRIP-FAULT)	•
4 LEDs selection of display mode (SCAN-AUTO-MAN-T-MAX)	•
1 LED to display the state of FAN1	•
Temperature control from 0°C to 240°C	•
2 alarm thresholds for channels 1-2-3	•
2 alarm channels for channel 4	•
2 ON-OFF thresholds FAN1 ventilation	•
Sensor diagnostics (Fcc-Foc-Fcd)	•
Data memory diagnostics (Ech)	•
Access to programming through front keyboard	•
Automatic exit from programming, display and relay test after 1 minute of inactivity	•
Incorrect programming warning	•
Selection between channels automatic scanning, hottest channel or manual scanning	•
Storage of maximum temperatures reached by channels and alarm status	•
Front key to reset the alarms	•
Voting Function	•
Fail Safe Function	•
WEB SERVER Wi-Fi Function	•
Internal clock maintenance in STATION (NTP server) and ACCESS POINT mode	•

FRONT PANEL

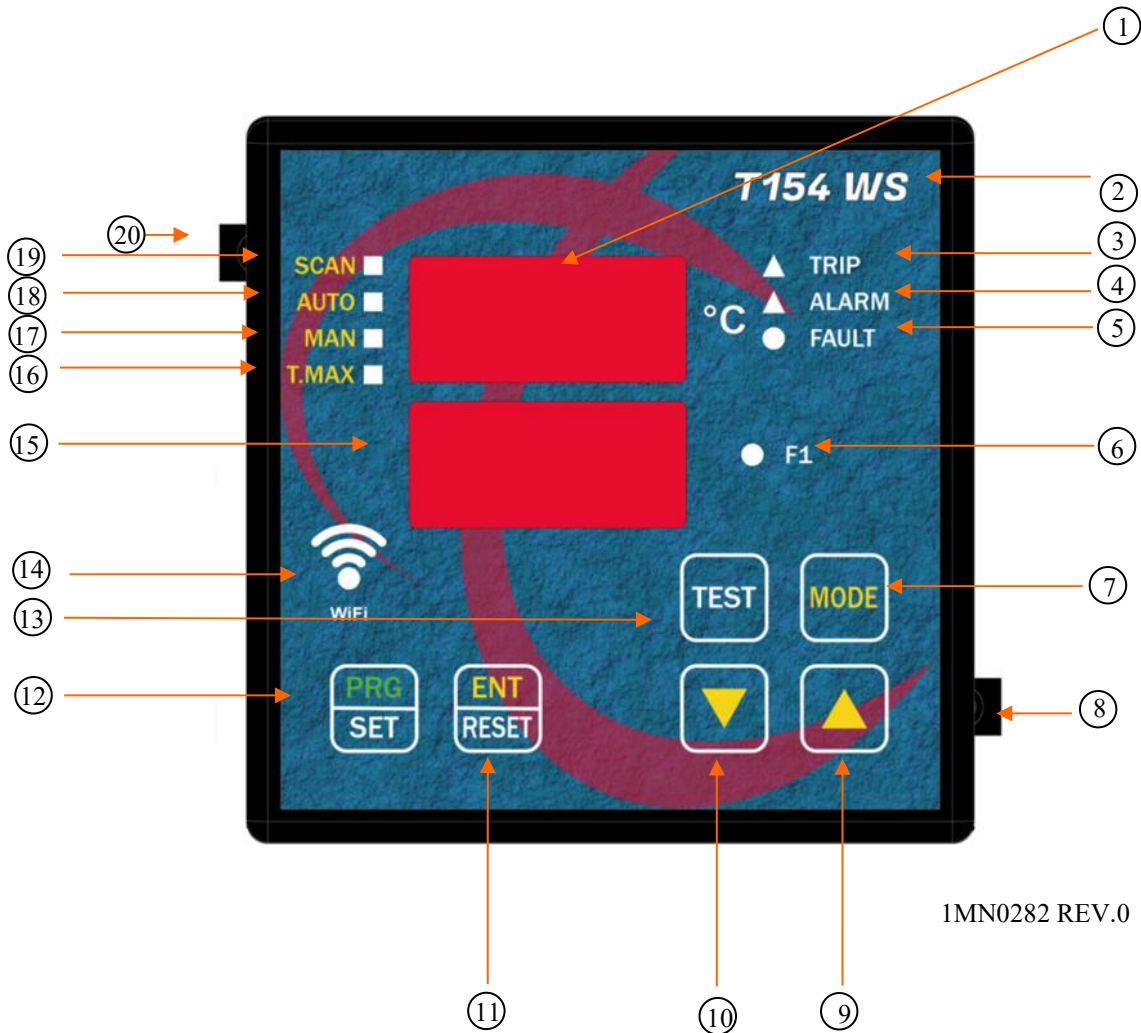

1MN0282 REV.0

1)	3-digit temperature display	11)	Enter/Reset button
2)	Control unit series	12)	Programming/Setting key
3)	TRIP (red) LED	13)	Led/relay test key
4)	ALARM (yellow) LED	14)	Wi-Fi (green) LED
5)	FAULT (red) LED	15)	3-digit channel display
6)	FAN 1 (yellow) LED	16)	T-max mode selection (red) LED
7)	Display mode selection and WIFI network activation key.	17)	Man mode selection (yellow) LED
8)	Fixing blocks	18)	Auto mode selection (green) LED
9)	UP key	19)	Scan mode selection (yellow) LED
10)	DOWN key	20)	Fixing blocks

DISPLAY

The first display is dedicated to temperatures.

The second display to the monitored channel.

When the device is turned on, or after a reset, the display always shows: the model of the T154 control unit, the type of probes, the temperature range, the VER "00" indication (firmware version) and the identification code of the WS device (web server).

Pressing the MODE key, the display modes can be set:

- **SCAN:** the control unit shows in scanning (every 2 seconds) all the enabled (°C) and disabled (NO) channels.
- **AUTO:** the control unit displays the hottest channel automatically.
- **MAN:** manual reading of the channel temperature using the up/down keys ▲ ▼
- **T.MAX:** The display shows the maximum temperature of the channel selected with the cursor keys. In the event of a fault, the Tmax value is replaced with the type of fault stored (fcc-foc). Turning on the Trip Alarm-Fault LED warns of any events that have occurred. The recordings are always successive to the moment in which the T.Max is reset (by pressing RESET).

OPERATING PROGRAM CONTROL

To control the protection levels programmed, press the PRG key twice to access the **VIS** programme. Repeatedly pressing the PRG key, you can scroll through all the previously loaded values in sequence.

After 1 minute's keyboard inactivity, the programming display procedure is automatically abandoned.

To stop the display, press the ENT key.

NOTES ON SCAN AND MAN FUNCTIONS

During the SCAN and MAN modes, the operation of the T154 WS can be displayed.

1) RUN CPU:

This message appears upon ignition of the device.

2) Ech Err:

This message appears when damage in the EEPROM memory is detected.

Pressing Reset will cancel the message and restore the original default parameters, listed in the programming paragraph on pages 13-14. Return the control unit to TECSYSTEM for repairs.

3) CAL Err:

This message appears when damage is found in the measurement circuit.

The temperature values displayed might be incorrect. Return the control unit to TECSYSTEM for repairs.

4) Pt Err:

This message appears when it is detected that one or more PT100 sensors are not working correctly, FOC, FCC and FCD indications in the temperature sensor diagnostics paragraph on page 16.

In case of **Err** the FAULT relay will be de-energised.

The above messages will be displayed following the 1-2-3-4 priority stated.

in any display mode in case of faulty sensor failure (fcc, foc or fcd) the control unit will automatically set up in **SCAN mode (PRIVILEGED SCAN)** allowing immediately displaying of the fault condition on the relative **CHn** channel (the **Mode** key is disabled).

LED TEST

We suggest carrying out the control unit LED test regularly.

For this operation, press the TEST key briefly; all the displays turn on for 2 seconds.

If one of the LEDS does not work, please return the control unit to TECSYSTEM for repair.

ALARM RELAY TEST

This function allows you to carry out a test of the relay operation without having to use further devices. To start the test procedure, press and hold the TEST button for approximately 5 seconds: the TST indication appears for 2 seconds confirming entry into the Relays Test mode.

The LED that is lit shows the relay to be tested; use the cursors ▲ ▼ to select the desired relay.

Press the SET and RESET keys to energise and de-energise the relay to be tested; the display will show ON-OFF.

After 1 minute's keyboard inactivity, the RELAY TEST procedure will be automatically abandoned.

To stop the RELAY TEST procedure, press the TEST key.

Alternatively, it is possible to use the PT100 model simulator: SIM PT100.

ATTENTION: Entering the relay test mode temporarily disables the failsafe function, relays with function enabled switch (ALARM-TRIP-FAULT).

ALARM RELAY SILENCING

To silence the ALARM signal, press the RESET key: the relay will de-energise and the ALARM LED, which is on steady, will start to flash. Silencing is automatically disabled when the temperature goes below the ALARM threshold.

WIFI NETWORK ACTIVATION

Activating the device's WI-FI network, ACCESS POINT mode, must be performed by pressing the MODE button for 5 seconds. The indication SET-WS will appear on the display for approximately 2 seconds. Enabling the WI-FI network will make the WIFI network of the device called TECSYSTEM visible and accessible for one minute. By starting the network search from a Smartphone, Tablet or PC and entering the network key, see procedure on page 21, it will be possible to access the WEB SERVER functions. The WI-FI network will be automatically disabled after one minute of inactivity or following forced disconnection by the user from the network.

ASSEMBLY

Drill a hole in the panel sheet with dimensions of 92 x 92 mm.

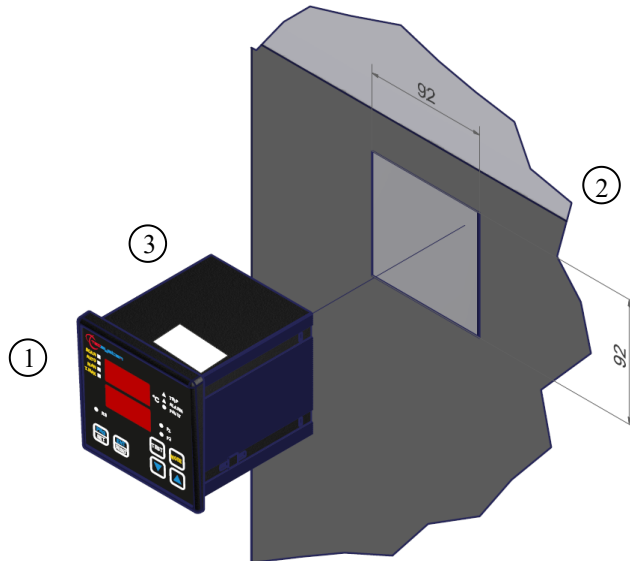

1MN0007 REV. 0

1)	Control unit	2)	Panel hole dimensions (+0.8 mm tolerance)
3)	Identification label		

Secure the appliance firmly by means of the supplied fixing blocks.

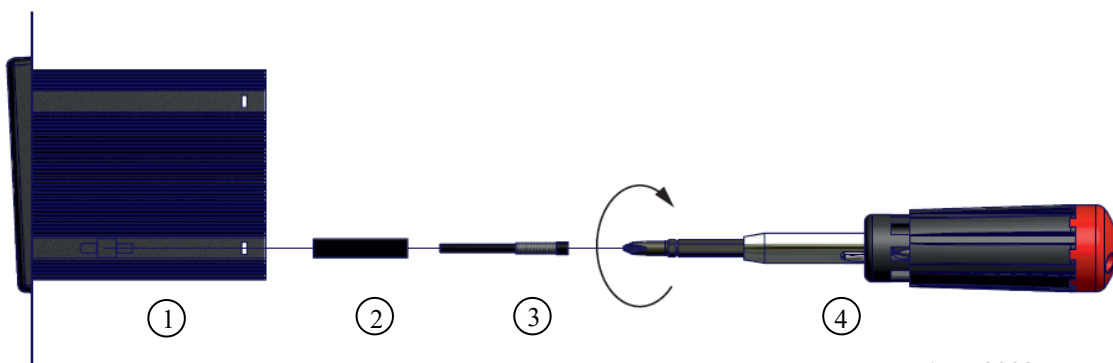

1MN0008 REV. 0

1)	Control unit	3)	Locking screws
2)	Fixing blocks	4)	Cross-head screwdriver #1X100mm

ELECTRICAL CONNECTIONS



The Wi-Fi antenna is integrated into the device.

T154 WS ED25

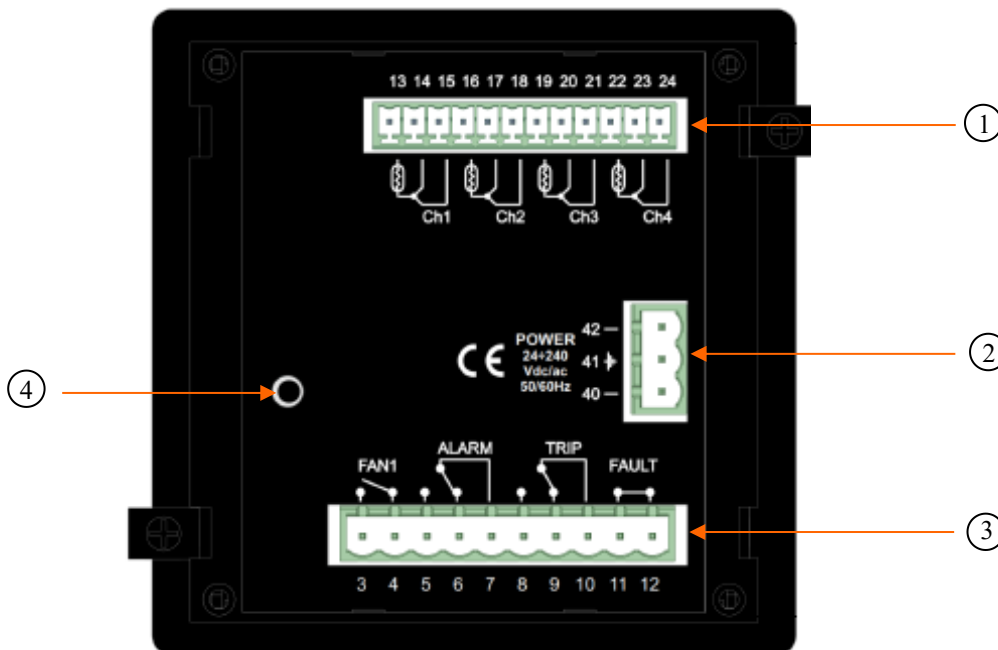

1MN0276 REV.0

1)	Pt100 sensors (white-red-red)	3)	Relays (FAN1-ALARM-TRIP-FAULT)
2)	Power supply 24-240Vac-cc 50/60Hz.	4)	Access point default connection key

Note: image relay contacts in non-alarm condition, except for the FAULT relay which switches: contacts 11-12 open (NO) contacts 11-12 closed (NC) fault condition identification. Read paragraph Alarms and Ventilation p. 12 and see image of fault contact opening.

RELAYS CONNECTION EXAMPLE

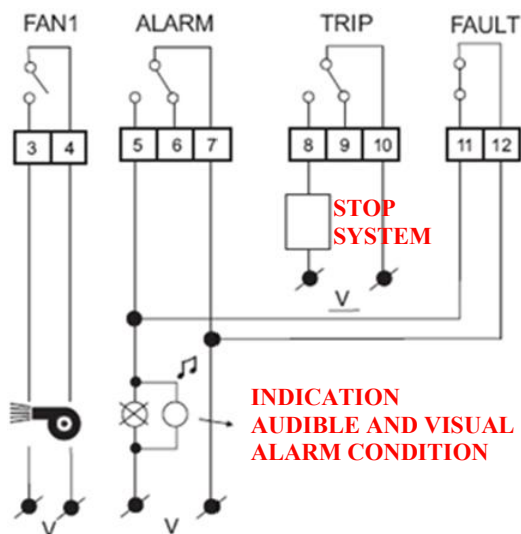

Output relay with contacts of 10A-250Vca-res $\cos\Phi=1$.

1MN0095 REV. 0

Pt100 CONNECTION EXAMPLE

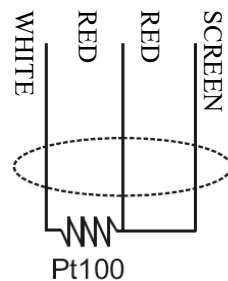

Note: before connecting the probes to the control unit, carefully read the paragraph measurement signal transfer on page 15.

POWER SUPPLY

The T154 WS control unit can be supplied by 24 to 240 Vac-Vdc, 50/60 Hz irrespectively of polarity in Vdc (terminals 40-42).

This particularity is obtained thanks to the use of a tested power supply, of new conception and realisation, which frees the installer from any uncertainty regarding the correct Vac or Vdc power supply.

The earthing cable must always be connected to terminal 41.

When the control unit is powered directly by the secondary of the transformer to be protected, it can be burnt out by high intensity overvoltages.

These problems occur if the main switch is closed and the transformer does not have the load (no load test).

The above is much more evident when the 220 Vac voltage is taken directly from the bars of the secondary of the transformer and there is a fixed capacitor battery for power factor correction of the transformer itself.

To protect the control unit against line overvoltages, the PT-73-220 electronic arrester, designed by TECSYSTEM S.r.l. for this specific purpose, is recommended. Alternatively, it is advisable to use 110 V AC supply voltages or, even better, 110 VDC.

If an existing control unit must be replaced with a new one, to guarantee its correct and safe operation, the sensor/relay/supply connecting terminals must be replaced with the new terminals supplied.

ALARMS AND VENTILATION

Carry out the electrical connections on the removable terminal blocks only after disconnecting them from the unit.

When the control unit is in one of the following modes, it does not perform any thermal monitoring, moreover the relays will all be disabled, the fault contact switches and the fault LED will flash.

- Vis. Programming display.
- PRG programming.
- Relay test.

The ALARM and TRIP relays only switch when the set temperature thresholds are exceeded.

The FAULT (fault) contact, programmed in active failsafe mode (default YES), opens (11-12) when the appliance is powered, only if during the access phase the control unit does not detect anomalies, and keeps the switching until when one of the following events occurs:

- Data memory fault (Ech message).
- Pt100 sensor fault (FCC short-circuited sensor, FOC interrupted sensor or Fcd quick temperature increase)
- CAL damage to the measurement circuit.
- Insufficient supply voltage.
- During the power on reset after programming (PRG), displaying the data (VIS) and relay test.

The FAULT failsafe mode can be disabled FAULT failsafe "NO" see programming step 30-31 page 14.

NOTE: in order to avoid unwanted system outages, do not connect the FAULT relay to the transformer tripping circuit.

FAULT CONTACT (failsafe active)

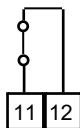

FAULT 11-12 NC: ALARM FAULT OR POWER OFF

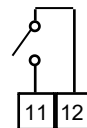

FAULT 11-12 NO: POWER ON OR NO FAULT

The FAN1 relay is able to manage cooling of the transformer or the environment in which the cabin operates, see the fan control paragraph on page 17.

NOTE: always disconnect the unit before performing any electrical connections.

FAULT AND RESET MESSAGE SEQUENCE





















Find below the sequence of fault messages and RESET function condition.

- | | | |
|-----------|----------------------------|--------------------------|
| 1) ECH | eeprom fault | erasable message |
| 2) CAL | measurement circuit fault | erasable message |
| 3) FCD | quick temp. increase fault | resettable condition |
| 4) ERR PT | FCC or FOC sensor fault | non-resettable condition |

PROGRAMMING

T154 WS ED25

PITCH	PRESS	EFFECT	PRESS	NOTES
1		Press and hold the PRG button until the display shows SET PRG		
2		Select PRG SET to proceed with programming or PRG 1 to load the default values		PRG 1 default data
3		The ALARM threshold for (CH 1-2-3) is displayed. Set the desired threshold, the Alarm LED flashes		Default 90°C
4		The TRIP threshold for (CH 1-2-3) appears and the Trip LED flashes.		
5		Set the desired threshold		Default 119°C
6		The display shows FAN1 (CH 1-2-3) Fan1 LED flashes.		Default YES
7		Select YES/NO		
8		The display shows (CH4) Enabling CH4		
9		Select YES or NO		with YES the CH4 is enabled with NO the CH4 is disabled
10		The ALARM threshold for (CH4) appears and the Alarm LED flashes.		If CH4=NO jump to step 16, Default NO
11		Set the desired threshold		Default 120°C
12		The TRIP threshold for (CH4) appears and the Trip LED flashes		
13		Set the desired threshold		Default 140°C
14		The display shows FAN1 for CH4		
15		Select YES/NO		Default NO
16		The display shows ON, FAN1 LED flashes		FAN1 NO jump to step 20
17		Set the desired threshold FAN1 ON		Default 70°C
18		The display shows OFF, FAN1 LED flashes		
19		Set the desired threshold FAN1 OFF		Default 60°C

20		HFN (NO) is displayed The FAN1 led flashes		Fan cyclic test for 5 min. every "n" hours
21		Set the desired number of hours	 	Default NO = function disabled
22		FCD (NO) is displayed		Fault for quick temperature of the temperature (°C/sec)
23		Set the desired value (FCD info on page 19)	 	Default NO (function excluded)
24		VOT (YES) is displayed (VOTING info on page 16)		
25		Select YES or NO	 	Default NO (function excluded)
26		FLS (ALARM) is displayed Blinking ALARM LED (info FAIL SAFE on page 18)		
27		Select YES or NO	 	Default NO
28		FLS (TRIP) is displayed Blinking TRIP LED		
29		Select YES or NO	 	Default NO
30		FLS (FAULT) is displayed Blinking FAULT LED		
31		Select YES or NO	 	Default YES
32		END is displayed		End of programming
33		Press ENT to save the set data and exit programming		incorrect programming of the LED values indicated (note 6)
34		Return to step 1		

PROGRAMMING NOTES

- 1) The MODE key allows reversing of the programming steps according to the sequence 28-26-8-1
- 2) The TEST key allows exiting programming without saving the modified data.
- 3) After 1 minute's keyboard inactivity programming is abandoned without saving the data.
- 4) During programming the control unit does not control/protect the monitored machine.
- 5) At the end of programming the control unit is restarted and the FAULT relay is disabled until the unit is fully restarted.
- 6) If pressing ENT, "Err" appears, it means that one of the following mistakes has been made:

ERR ALL. = ALARM \geq TRIP
ERR FAN = FAN-OFF \geq FAN-ON. (FAN1)

The device automatically prepares itself for the programming step of the error committed

NOTE: EVERY TIME THE CONTROL UNIT PROGRAMMING, WITH CONFIRMATION OF DATA SAVING, THE VALUES STORED IN T-MAX ARE RESET AT THE TIME OF STORING.



ATTENTION:

We recommend you check the device's programming before starting the device.

The default parameters set by TECSYSTEM might not match your requirements.

Programming the device is the end user's responsibility, the settings of the alarm thresholds and the enabling of the functions described in this manual must be checked (by a specialist engineer) according to the application and features of the system the control unit is installed on.

TEMPERATURE SENSORS

Each Pt100 thermometric sensor has a white conductor and two red ones (CEI 75.8 standards).

The CH2 channel must always refer to the central column of the transformer.

The CH4 channel must refer either to the transformer core, or to the Pt100 room sensor whenever it is necessary to thermostat the transformer room using the T154 WS control unit.

MEASUREMENT SIGNAL TRANSFER

All the Pt100 measurement signal transfer cables must strictly comply with the following rules:

1. Every Pt100 must be connected with a three-wire cable with a minimum section of 0.35mm^2 and a maximum of 1mm^2 .
2. The extension cable must be screened with tinned copper braid with an 80% cover
3. Conductors must be twisted, maximum recommended step 60mm
4. The cable screening must only be earthed with a termination, preferably on the control unit side.
5. The sensors' signal transfer cable must not be near electrical cables, either low or medium-high voltage.
6. The Pt100 cable and the signal transfer cable must be laid in a straight line, without any winding.
7. Any caps used to butt conductors must be crimped properly to avoid false contacts.

NOTE: to install the sensors and signal transferring cable correctly, read the SCS/PT100 SENSORS installation note manual.

What may happen when installation rules are not complied with.

1) The electrical field propagating from the power line of another circuit couples capacitively with the conductors (in particular with unscreened cables). The effect of this coupling creates a signal that overlaps the signal transmitted by the nearby conductors, causing incorrect readings.

2) The variations in magnetic flux in the power lines may induce an electromotive force on the signal transferring cables (in particular non-twisted cables), that, being a closed circuit, generates a current. This interference current, multiplied by the circuit resistance, gives a voltage value that overlaps the signal to be transmitted, distorting the sensor measurement.

3) False contacts can alter the signal with the consequent variation in the temperature detected.

In specific cases, when the rules for connecting the Pt100 sensors are not complied with, the following anomalies can occur between the SCS box and the temperature control unit:

- a) incorrect temperature readings, alarms or anomalous tripping
- b) mechanical/electrical fault of the Pt100 sensors
- c) damage to the Pt100 inputs of the control unit.

TECSYSTEM S.r.l. has designed its own special cable to transfer the measurement signals, CEI-compliant, with all the protection requirements provided for mod. CT-ES

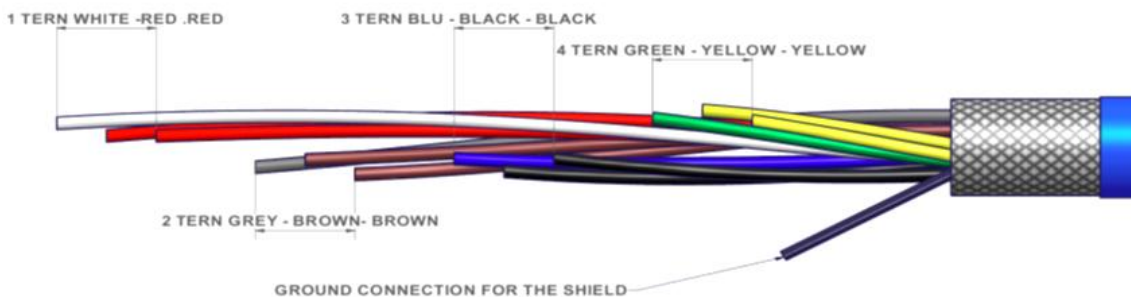

NOTE: the use of cables not complying with the above could cause possible reading anomalies. It is always important to take into account that any interference on the signal lines might cause anomalies on the Pt100 inputs (CH1-CH2-CH3-CH4) or on the sensors themselves.

All "T" series control units have linearity of the sensor signal, with a maximum error of 1% of full scale value.

TEMPERATURE SENSOR DIAGNOSTICS

In case of failure or exceeded full scale value of one of the thermometric sensors installed on the machine to be protected, the FAULT relay opens immediately with the relative warning of faulty sensor on the corresponding channel.

Fcc indicates sensor short-circuited or minimum full scale value of the control unit exceeded -8°C .

Foc indicates sensor interrupted or maximum full scale value of the control unit exceeded 243°C .

To eliminate the message and to restore the Fault contact opening, check the connections of the Pt100 and replace the faulty sensor if necessary. In case the minimum/maximum full scale value has been reached, make sure that the environmental conditions correspond to what is indicated by the control unit.

Note: exceeding the minimum/maximum full scale can also be caused by possible disturbances on the sensor lines, in this case the following are recommended:

Check correct installation of the sensors and especially of the extension cable (as indicated in the paragraph MEASUREMENT SIGNALS TRANSFER).

Activation of the functions: VOTING (shown below) or FCD (on page 19) in relation to the system conditions.

CAL message display: the indication appears when the measurement circuit is damaged. The temperature values displayed might be incorrect. Return the control unit to TECSYSTEM for repairs.

VOTING FUNCTION

The voting function derives from the redundancy concept that consists in duplicating the components of a system to increase their **reliability**.

How does VOTING work?

Using the redundancy principle, we use the sensors installed on the three phases U-V-W to monitor the transformer's operation, and at the same time to ascertain the sensors are working correctly, discriminating against any false alarms (generated by installation errors).

By activating the **VOTING "YES"** function, the control unit compares the temperature values recorded on the monitored CH1-CH2-CH3 channels and enables the switching of the (**TRIP**) disconnect contact only if the **TRIP** threshold has been exceeded on at least two channels over the same period T.

By selecting **VOTING "NO"** the function will be disabled.

Note: if Voting "Yes" is programmed, the switching of the **ALARM** contact will signal exceeding of the alarm threshold on each individual channel.

To enable the Voting function, read the programming section on pages 13-14.



Attention: To control the transformer correctly from a temperature point of view, enabling the VOTING function is allowed where the load distributed between the phases of the transformer is adequately balanced. In addition, any conditions of FAULT: FCC-FOC-FCD on two or more channels, with active voting, can determine the TRIP contact inhibition.

PROGRAMMED DATA DIAGNOSTICS

In case of failure of the internal memory or corruption of programmed data, just after switching on, **Ech** appears with the relevant Fault contact signal.

In this case, for safety reasons, the default parameters are loaded automatically (see programming table on pages 13-14).

Eliminate the **Ech** indication by pressing RESET and run programming to enter the desired values.

Finally switch the unit off and back on to check the memory works correctly, if it is damaged **Ech** will be displayed again (send the control unit to TECSYSTEM srl for repairs).

TEMPERATURE DIAGNOSTICS

When one of the thermometers detects a temperature higher than 1 °C with respect to the pre-set value as the alarm limit, after approximately 5 seconds the **ALARM** relay switches and the channel **ALARM** LED (CHn) switches on.

When the trip temperature limit is exceeded, after approximately 5 seconds the **TRIP** relay switches and the channel **TRIP** LED (CHn) switches on.

As soon as the recorded temperature returns to values equal to or lower than the limit set for the **ALARM** and **TRIP** relays switching, these relays de-energise and the corresponding LEDs switch off.

The values of **ALARM** and **TRIP** are kept in the internal memories: they can be recalled by entering the Vis modes (displaying programmed parameters) and modifiable in the PRG mode (programming).

COOLING FAN CONTROL

The T154 WS control unit has a FAN contact (FAN1). If properly programmed, it can control the ON-OFF of the fans for cooling of the transformer.

The contact of FAN1 is able to manage the cooling of the transformer or of the environment in which the cabin operates. The fans can be controlled in two different ways:

- Using the temperatures sensed by the sensors on the three columns **CHF** 1.2.3 (e.g. ON at 90°C - OFF at 70°C)
- Through an additional probe (**CH4/YES**) dedicated to the ambient temperature inside the transformer room **CHF** 4 (e.g. ON at 45°C - OFF at 35°C)

The ON and OFF values are programmable according to the device range. The FAN ON must always be at least 1°C higher than FAN OFF (recommended Δ FAN = ON_OFF +10°C).

The FAN 1 LED comes on when the temperature exceeds the FAN ON threshold by 1°C. The relative relay switches, and turns off when the temperature goes below 1°C of the FAN OFF threshold. The relative relay switches go off when the temperature goes below 1°C of the FAN OFF threshold and the relative relay switches.

FAN TEST

It is possible, by programming (**HF_n**), to make sure that the fans are operated for 5 minutes every xxx" hours, regardless of the temperature values of the columns or the environment (e.g.: with HF_n = 001 the fans are activated for 5 minutes every hour).

This function is designed to periodically check the operation of the fans and of their control equipment.

Setting **NO**, this function is inhibited.

To enable the HF_n function, read the programming section on pages 13-14.



IMPORTANT INFORMATION

Before carrying out the isolation test of the electrical panel the control unit is installed on, disconnect it together with the sensors from the power supply to prevent it from being seriously damaged.

FAILSAFE FUNCTION

The T154 WS control unit has the selection n.o (normally open contact) / n.c (normally closed contact) for the ALARM, TRIP and FAULT relays, programming steps from 26 to 31 page 14. Selecting the YES/NO setting introduces the Fail Safe and No Fail Safe functions.

ALARM AND TRIP

By setting NO (NO Fail safe) the normally open contacts are in positions 5-7 Alarm and 8-10 Trip, they switch only when the pre-set temperature limits are reached.

By setting YES (Fail safe), the normally closed contacts are in positions 5-7 Alarm and 8-10 Trip, they switch only when the pre-set temperature limits are reached or as a result of no voltage.

FAULT

By setting YES (Fail safe), contact 11-12 is positioned as normally open, switches (closed) when a fault condition is identified; see paragraph on alarms and ventilation on page 12.

Setting NO (NO Fail safe) the contact 11-12 is positioned as normally closed, switches (open) when a fault condition is identified; see paragraph on alarms and ventilation on page 12.

If the fail safe function is disabled on the fault contact, the control unit will no longer be able to signal the fault due to power failure. In this case it is advisable to enable the Fail safe on the ALARM contact for the afore-mentioned indication.

NOTE: when the control unit is in one of the modes indicated below, it does not perform any thermal monitoring, moreover the relays will all be disabled the FAULT led will flash.

- Vis. display programming.
- PRG programming.
- Test of the relays.

The FAIL SAFE function is temporarily disabled and the FAULT relay switches.

ATTENTION: Entering the relay test mode temporarily disables the failsafe function. The relays with function enabled switch (ALARM-TRIP-FAULT).

TECHNICAL SPECIFICATIONS OF THE EXTENSION CABLE FOR Pt100

1. Cable 20 x AWG 20/19 Cu/Sn
2. Section 0.55 mm²
3. Flame-protection insulation PVC105
4. Standards CEI 20.35 IEC 332.1
5. Maximum operating temperature: 90°C
6. Configuration: 4 triples of three twisted and coloured conductors
7. Screen on Cu/Sn
8. Fireproof PVC sheath
9. Outer diameter 12 mm
10. Standard configuration in 100 m coils

FCD FUNCTION

The T series equipment boasts an innovative control function combined with the dynamic status of the Pt100 sensor.

Activating FCD, the control unit analyses the increase in temperature ΔT (*) recorded in a second (**°C/sec**).

Enabling the function, the user can select the value (ΔT) from a minimum of 1°C/sec up to a maximum of 30°C/sec. **If the measured value is higher than the value set by the user**, the control unit inhibits any activation of the ALARM and TRIP alarms and activates the switching of the FAULT relay (11-12), signalling on the display "**fault for Fcd**".

e.g. setting the function to 5°C, the fault switching for FCD will only be activated if the control unit detects an increase ΔT higher than 5°C in one second on the monitored system.

Setting "no" the FCD function is disabled.

When a channel is in Fault for FCD, the relative alarm and trip signals are inhibited on the single channel; therefore only the anomaly of excessively rapid increase of the temperature is signalled.

Press Reset to cancel the FCD signals of all the channels and reset the relay fault.

Possible applications of FCD

Identification of a possible induced interference on the Pt100 sensor line

If the installation instructions are not complied with (see page 15), any interference on the Pt100 sensor line can cause false readings or anomalous alarms.

Setting the FCD function in a temperature range of between 1°C and 10°C (5°C recommended), the effects caused by false readings can be suppressed and the alarm relay activation can be prevented, as shown above.

Corrective actions: check the installation of the sensor extension cable is in line with the instructions given in the paragraph on the measurement signal transfer on page 15.

Identification of a sensor fault or faulty connection

In case of a faulty connection or sensor fault, a quick positive or negative variation in temperature might occur, leading to the system tripping or the alarms of the monitored system to be triggered.

In this specific case we recommend the FCD function to be set in a temperature range of between 10°C and 20°C.

Corrective actions: check the terminals the sensor is connected to are tightened and replace the faulty sensor, if required.

Identification of the electrical motor rotor block

In case of temperature control of the electrical motors, the quick temperature increase might be due to a blocked rotor.

In this specific case, it is advisable to set the FCD function in a temperature range of between 20°C and 30°C. This setting is recommended in order to avoid activation of the FCD function during the motor starting phase, i.e. where the increase ΔT /sec. has a very rapid variation.

(*) The ΔT value shows the temperature range for each second.

NOTE: it is advisable not to enable the FCD function with VOTING active.

T154 WS WI-FI CONNECTION

The T154 WS control unit has a built-in **WEB SERVER** that is accessible via Wi-Fi connection.

What is needed to access the **T154 WS** control unit?

To access the web server a device with a Wi-Fi connection and an Internet browser is needed.

How to connect on the first start? "**Access Point**" mode

Press the MODE key, for at least 5 seconds, the indication SET-WS will appear on the display for about 5 seconds.

Launch the search for Wifi networks from your device (PC, Smartphone or Tablet).

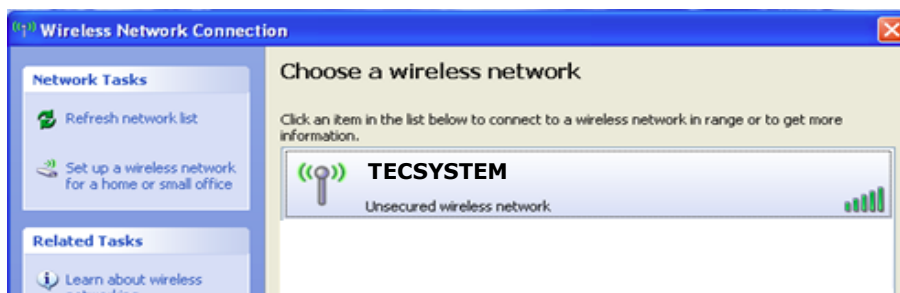

NOTE: the name of the network to connect to is TECSYSTEM, the network will be available for 1 minute after which the network will no longer be visible.

Select the **TECSYSTEM** network.



Click on **CONNECT**

The TECSYSTEM network requires the insertion of a digital network key: **TECSYSTEM** in the **network key** window, repeat the operation in the **network key confirmation** window.



Click on **CONNECT**

Once the connection is established, your device will indicate **Connected TECSYSTEM**.



NOTE: Connecting to the T154 WS network will result in automatic disconnection from other networks; for devices such as Smartphones or Tablets it may be necessary to disable the data connection.

Having connected to the **TECSYSTEM** network open your browser program and type in the address 192.168.8.8, that follows on page 21.

ACCESS POINT RESET MODE

I have set the web server to Access point or Station mode but I cannot identify the network or access the web server.

Power the control unit by holding down the button on the back for about 5 seconds.

The access point button allows the user to temporarily access the web server in "Access Point" mode by forcing operation with the IP address 192.168.8.8.

How it works:

With the control unit off, keep the access point button pressed, then power the device and release the button after about 5 seconds

Start the network search and connection as escribed on the above procedure.

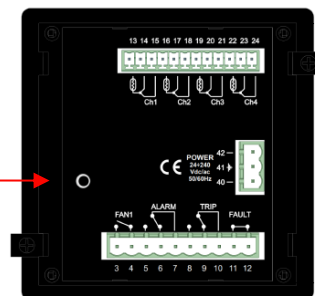

TECSYSTEM WEB SERVER

Through the Wi-Fi connection, the TECSYSTEM WEB SERVER interface allows the user to access all the information present on the web server integrated in the T154 WS.

To take full advantage of the product features it is advisable to connect the T154 WS to a Wi-Fi network (STATION mode). The Wi-Fi connection will allow you to manage multiple control units under a single network and to control them from any device connected to the network. The NTP Server setting (time.google.com or other), see STATION options page 24, will allow automatic updating of date and time.

The **STATION** or **ACCESS POINT** operating mode is displayed at the bottom of the page on the temperatures and alarms screen:

- **WI-FI CONNECTED TO - NETWORK NAME (dBm signal reception level) - MODBUS RUNNING (STATION)**
- **WI-FI DISCONNECTED - MODBUS RUNNING (ACCESS POINT)**

NOTE: in the **Access point** functions, the device automatically keeps the date and time, through a back-up battery, set at the first start-up. By accessing the "Options" page, it will be possible to set the date/time data manually, see page 25.

The data collected on the web server is divided into 6 screens:

- **Presentation** screen
- **Home Screen** (Device serial number, firmware version and web server version)
- **Temperatures and alarms** screen (screen selection pages)
- **Settings** screen (measured temperatures and channel status)
- **Graphics** screen (T154 WS device programming and web manager settings)
- **Event log** screen (display of temperature graphs and CHn channel data export)

Open your browser and enter the address: **192.168.8.8**

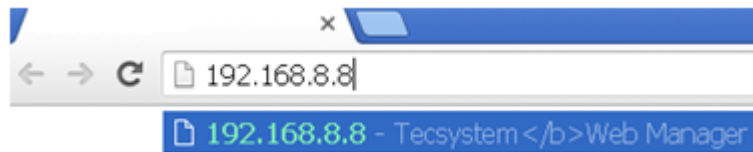

Select **192.168.8.8 Tecsystem Web Server**, press **ENTER**.

The web manager's presentation page will appear for a few seconds, showing the model of the control unit, the serial number of the device and the year of production, its firmware version and the web server version.



HOME SCREEN

The home screen allows the user to identify the cabin and to select the various screens.

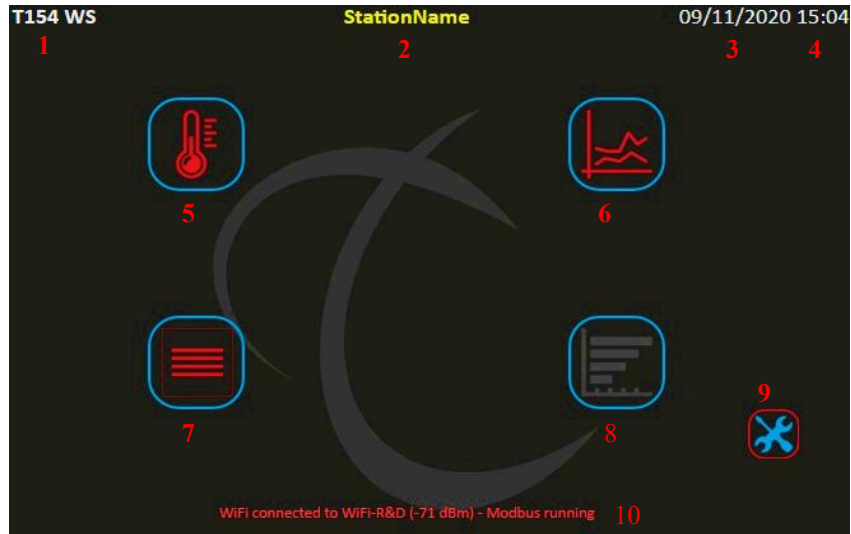

The following information is shown in the management screen:

1	Control unit model	6	GRAPHICS screen selection key
2	Station Name or monitored cabin (*)	7	EVENT LOG screen selection key
3	Reference date	8	STATISTICS screen selection key (Not available for the T154 WS model)
4	Reference time	9	SETTINGS screen selection key
5	TEMPERATURES AND ALARMS screen selection key	10	Network name and signal level (info page 21)

(*) The Station Name indication can be customised by the user in the options- labels settings screen, see page 25. Pressing the selection keys 5-6-7-8 it is possible to access the various screens; the web manager will display only one screen at a time.

TEMPERATURE AND ALARMS SCREEN

The temperatures and alarms screen shows the operating status of each channel, i.e.: the temperature detected by each channel, the FCD-FOC-FCC sensor fault indications, activation of the F1-ALARM-TRIP alarms.



TEMPERATURE & ALARM									
1	2	3	4	5	6	7	8	9	10
CH	VALUE	LABEL	FCD	FOC	FCC	F1	F2	ALR	TRP
1	38 °C	CH1	•	•	•	•	•	•	•
2	64 °C	CH2	•	•	•	•	•	•	•
3	43 °C	CH3	•	•	•	•	•	•	•
4	NO °C	CH4	•	•	•	•	•	•	•



Key: **BACK**
Return to the
HOME screen

1	Channel indication CH1-CH2-CH3-CH4	6	FCC signal ON red LED
2	Channel temperature CH1-CH2-CH3-CH4	7	F1 signal ON yellow LED (FAN1)
3	Channel reference label (*)	8	F2 signal ON yellow LED (FAN2) (Not available for the T154 WS model)
4	FCD signal ON red LED	9	ALR signal ON red LED (ALARM)
5	FOC signal ON red LED	10	TRP signal ON red LED (TRIP)

(*) the label indication can be customised by the user in the options – labels settings screen, see page 25.

SETTINGS SCREEN

In the settings screen it is possible to modify the programming of the T154 WS control unit.



Key: **BACK**
Return to the
HOME screen

1	Channel reference and enabling CH1-CH2-CH3 and CH4	10	Enabling of FAILSAFE FUNCTION Relay: ALARM-TRIP-FAULT
2	Enabling FAN 1 channel CH1-CH2-CH3	11	FAN 1 limit programming boxes On and Off (from 1°C to 240°C)
3	Enabling FAN 2 channel CH4 (Not available for the T154 WS model)	12	FAN 2 limit programming boxes (Not available for the T154 WS model)
4	INTELLIFAN FUNCTION enabling (Not available for the T154 WS model)	13	NETWORK SETTINGS key
5	ALARM limit programming box (from 0°C to 239°C)	14	E-MAIL SETTING key (Not available for the T154 WS model)
6	TRIP limit programming box (from 1°C to 240°C)	15	OPTIONS button
7	HFN setting box (from 0h to 200 h) 0= function disabled	16	SAVE SETTINGS key
8	FCD setting box (from 0°C to 30°C) 0= function disabled	17	PIN CODE box (*)
9	Voting setting box: (0-NO) (1-YES)		

As for the panel programming also for programming through WEB SERVER it is necessary to follow these rules:

AL. = ALARM \geq TRIP

FAN = FAN-OFF \geq FAN-ON. (FAN1)

The cells of the editable values are accessible in white, the grey cells are not accessible. The programming limits of the monitored parameters are shown in the table above.

SAVE SETTINGS key



After entering the **PIN CODE**, default 00000, by pressing the **SAVE SETTINGS** key the user updates the programming data of the T154 WS device. The control unit will lose the connection for a few seconds, the device will start after which the new values will be available on the updated screen.

Incorrect programming of the device will result in the display of an error POP UP window with the relative signalling; the data update will not be processed.

(*) Note: PIN CODE settings and operation on page 28



ATTENTION:

We recommend you check the device's programming before starting the device.

The default parameters set by TECSYSTEM might not match your requirements.

Programming the device is the end user's responsibility, the settings of the alarm thresholds and the enabling of the functions described in this manual must be checked (by a specialist engineer) according to the application and features of the system the control unit is installed on.

NETWORK SETTINGS key

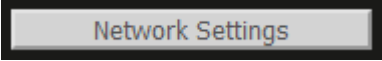

Pressing the NETWORK SETTINGS button the user accesses the Wireless network setting screen. In this screen the user can select the STATION or ACCESS POINT operating mode and set the network parameters.

WIRELESS MODE

it allows the user to select the operating mode.

STATION: the web server is connected via WI-FI to a pre-established network.

ACCESS POINT: the device works in the indicated mode, creating its own independent Wi-Fi network.

STATION MODE SETTINGS

Setting of the defined network parameters to which the control unit is connected.

ACCESS POINT MODE SETTINGS

Setting of network parameters: **SSID** (network name) and **Password** of the network to which the control unit is connected.

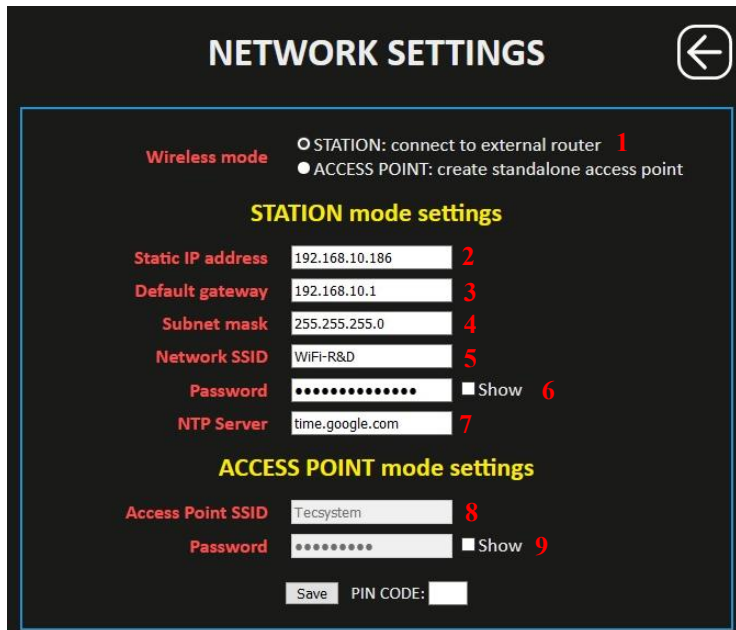

NOTE: For information/clarifications regarding the Wi-Fi network connection, contact your IT MANAGER.

1 Selection STATION mode settings			
2	Static IP address	5	Wi-Fi network name (Wi-Fi network on which to connect the device)
3	Default gateway	6	Wi-Fi network password (SHOW to view the password)
4	Subnet mask	7	Server NTP address (automatic time and date update)
1 Selection ACCESS POINT mode settings			
8	Access Point SSID (default TECSYSTEM) (network name modification)	9	SSID password (TECSYSTEM default) (SHOW to view the password)

After entering the **PIN CODE**, default 00000, press **SAVE** to save the set values. A POP UP window will confirm correct saving of data.

Note: PIN CODE settings and operation on page 28.



Press **BACK** to return to the previous screen

OPTIONS button

Options

Pressing the **OPTIONS** button accesses the options screen. On this page it is possible to: set the date and time in the Access Point mode, select the sampling interval, customise the labels (labels) station and channels and set the username and password useful to access the web server.

Set data/time (AP mode) allows the user to manually set the date and time in AP mode. This information is essential for correct operation of the control unit.

Temperature Sampling Interval

The sampling interval represents the waiting time between one recording and the next, a fixed pre-set value of 15 minutes.

Event log

✓ FAN ON/OFF event log recording enabling flag. NOTE: when the FAN event is enabled, the maximum recording limit, 1,000 events, may be reached early.

✓ TRIP event log recording enabling flag when the TRIP threshold is reached.

Labels

The labels are used to customise, as desired, identification of the control unit and of the individual channel.

The Web Access Credentials setting

It is used to set **username** and a **password**. Upon each log in to the web server, a POP-UP credential window will appear.

The screenshot shows the 'OPTIONS' screen with the following settings and callouts:

- 1: Set date/time (AP mode only)
- 2: Temperature Sampling Interval (15)
- 3: Event log (Include FAN ON/OFF events)
- 4: Event log (Include TRIP temperature events)
- Labels section:
 - 5: Station Name label (bets zero)
 - 6: Channel 1 label (CH1)
 - 7: Channel 2 label (CH2)
 - 8: Channel 3 label (CH3)
 - 9: Channel 4 label (CH4)
 - 10: Channel 5 label (undefined)
 - 11: Channel 6 label (undefined)
 - 12: Channel 7 label (undefined)
 - 13: Channel 8 label (undefined)
- Web Access Credentials section:
 - 14: Username
 - 15: Password (with Show checkbox)

1	Date and time setting in mode Access point mode	2	Sampling interval 15 minutes
Events			
3	Include FAN ON/OFF log records	4	Include TRIP achievement log records
Labels			
5	Station Name label	10	Channel 5 label (only NT538 WS)
6	Label channel 1	11	Channel 6 label (only NT538 WS)
7	Label channel 2	12	Channel 7 label (only NT538 WS)
8	Label channel 3	13	Channel 8 label (only NT538 WS)
9	Label channel 4		
Web Access Credentials (setting of Username and Password for Web Server access)			
14	Username	15	Password (SHOW for password verification)

After entering the **PIN CODE**, default 00000, press **SAVE** to save the set values. A **POP UP** window will confirm the correct saving of data.

Note: PIN CODE settings and operation on page 28.



Press **BACK** to return to the previous screen

GRAPHICS SCREEN

The **Graphics** screen allows the user to view the temperature trend of the CH1-CH2-CH3-CH4 enabled channels. it is also possible to export the values recorded on the CSV file.

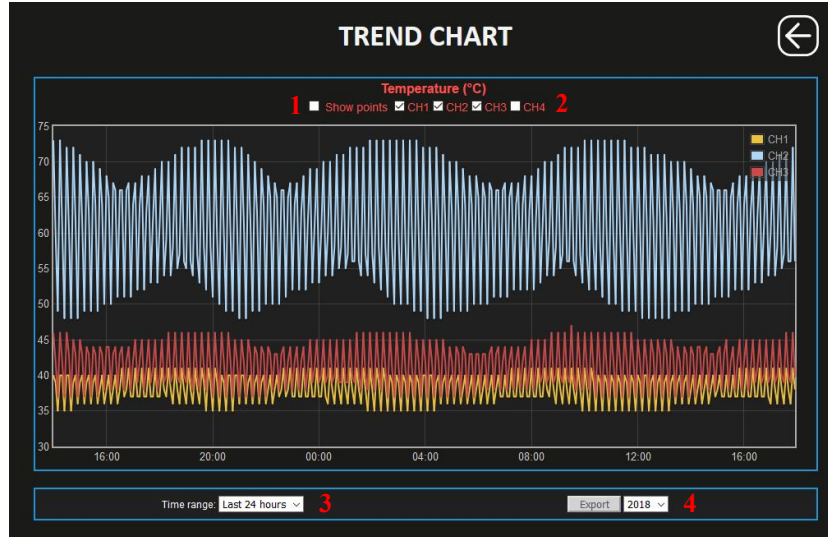
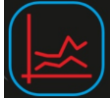

Key: **BACK**
Return to the
HOME screen

1	Recording points display flag	3	Time range
2	CHn channel enabling flag	4	Export key

Recording points display flag

Enabling the recording points display flag it will be possible to identify each recording in the graph. Clicking on the individual point will show the information of: channel, date, time and recorded temperature value.

CH2: 15/7/2020, 16:20:00 72°C

CH channel selection flag

Enable / disable the graphic display of the individual CHn channel.

Time range

Time range: Last 24 hours ▾

Allows the user to set the graphical display period available in the following selections:

- Last 24 hours
- Last 7 days
- Last 30 days

The trend display, channel temperatures, will be updated according to the selection of the chosen period and the enabled channels.

EXPORT button

Export

By pressing the **EXPORT** button, all the temperature values recorded can be downloaded in CSV format (text file).
CSV file export note on page 28.

EVENT LOG SCREEN

The Event log screen is used to quickly obtain an immediate overview of the events recorded by the control unit. Each event is identified with ID code, see event ID table.



Key: **ORDER**
It is used to organise the order of the events according to the display requirements.

ID #	DATE/TIME #	DESCRIPTION	CH #	VALUE #
R05	15/7/2020, 14:12:14	ALARM OFF	3	72 °C
R05	15/7/2020, 14:11:48	TRIP OFF	3	73 °C
W04	15/7/2020, 14:11:43	undefined		
S06	15/7/2020, 14:10:50	TRIP ON	3	74 °C
S05	15/7/2020, 14:10:26	ALARM ON	3	73 °C
W04	15/7/2020, 14:10:21	undefined		
S03	15/7/2020, 14:09:57	FAN 1 ON	3	71 °C
I01	15/7/2020, 14:05:08	REAL-TIME CLOCK SYNC OK		
I05	15/7/2020, 14:04:25	WIFI CONNECTED		
I03	15/7/2020, 14:04:22	WIFI STATION MODE STARTED		
I00	15/7/2020, 14:04:21	SYSTEM RESTARTED		
R05	15/7/2020, 13:51:32	ALARM OFF	3	72 °C
S05	15/7/2020, 13:50:20	ALARM ON	3	73 °C
W04	15/7/2020, 13:50:06	undefined		
S03	15/7/2020, 13:49:35	FAN 1 ON	3	71 °C
R03	15/7/2020, 13:44:08	FAN 1 OFF	3	49 °C
R05	15/7/2020, 13:36:08	ALARM OFF	3	72 °C
S05	15/7/2020, 13:34:46	ALARM ON	3	73 °C
W04	15/7/2020, 13:34:41	undefined		
S03	15/7/2020, 13:34:12	FAN 1 ON	3	71 °C
R03	15/7/2020, 13:28:46	FAN 1 OFF	3	49 °C
R05	15/7/2020, 13:20:44	ALARM OFF	3	72 °C
S05	15/7/2020, 13:19:23	ALARM ON	3	73 °C



Key: **BACK**
Return to the **HOME** screen

1	Export key	4	Date Description
2	Event ID	5	Event channel numbering
3	Date / Time	6	Temperature value recorded

EXPORT button

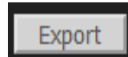

By pressing the **EXPORT** key it is possible to download all the recorded events in CSV format (text file), see notes on page 28

ID events table

Code	Message	Description
I00	System restarted	web server start
I01	Real time clock sync	Automatic setting date and time via sync server
I02	Login successful	web server access
I03	web server in STATION mode start	Start mode web server in STATION
I04	Wi-Fi Access point started	web server in ACCESS POINT mode start
I05	Wi-Fi connected	Web server connected to the Wi-Fi network
I06	Setting saved	Control unit parameters saving (PRG)
I07	Temperature log saved to csv	Csv temperature file saving
I08	Event log saved csv	Csv event log file saving
W00	Wi-Fi not connected	Wi-Fi disconnected from the network
W01	Real time clock set to last saved	Reset date and time, automatic, from the last saving
W02	Real time clock manually set	Manual date and time setting
W03	Diagnostic button pressed	The access point button has been pressed
W04	TRIP temperature reached	Reaching of the TRIP threshold on the identified CHn (option screen enabling flag)
R00	Fcc off	FCC OFF fault signal on CHn channel identified
R01	Foc off	FOC OFF fault signal on CHn channel identified
R02	Fcd off	FCD OFF fault signal on CHn channel identified
R03	Fan1off	FAN1 OFF switch off signal on CHn channel identified
R04	Fan2off	FAN2 OFF switch off signal on CHn channel identified
R05	Alarm off	ALARM OFF switch off signal on CHn channel identified
R06	Trip off	TRIP OFF switch off signal on CHn channel identified
S00	Fcc on	FCC ON fault signal on CHn channel identified
S01	Foc on	FCD ON fault signal on CHn channel identified
S02	Fcd on	FCD ON fault signal on CHn channel identified
S03	Fan1on	FAN1 ON activation signal on CHn channel identified
S04	Fan2on	FAN2 ON activation signal on CHn channel identified
S05	Alarm on	ALARM ON activation signal on CHn channel identified
S06	Trip on	TRIP ON activation signal on CHn channel identified
E00	Modbus error	Modbus error signal
E01	Internal error	Signal internal web server error
E02	Log index recovered	Reporting restoring of event log indices
E03	Log index cleared	Reporting deletion of event log indices

GRAPH DISPLAY NOTES

When opening the graphs page, the last seven days recorded are displayed by default; if seven days are not available in memory, all the available data are displayed.

The time range allows the user to set the graphic display period. The selections available are: last 24 hours, last 7 days and last 30 days.

CSV FILE EXPORT NOTES

After exporting the CSV file for **EVENT LOG**, all the recorded events are exported, up to 1000 events. Timing recording with date and UTC (coordinated universal time) time.

After exporting the **TEMPERATURE VALUES** CSV file, it will be possible to export a year of recorded data; if there is less than a year in memory, all the available data are exported. Timing recording with date and UTC (coordinated universal time) time.

PIN CODE

The **PIN CODE** is a five-number user-programmable code to confirm the user's intention to change device programming or network settings. It represents the programming key reserved for the system manager: it limits any risks of unauthorised changes or programming errors.

Without the **PIN CODE**, or with the incorrect **PIN**, programming of the device cannot be performed remotely.

How to change the PIN CODE:

Turn off the device and turn it on again by keeping the access point button on the back pressed for approximately 2 seconds.

Connect to the device and type, on the browser screen, the IP address <http://XXX.XXX.XX.XXX/setpin.html> .

(IP ADDRESS)

Example:   192.168.10.181/setpin.html

Pressing **ENTER**, the **SET PIN CODE** screen will open.

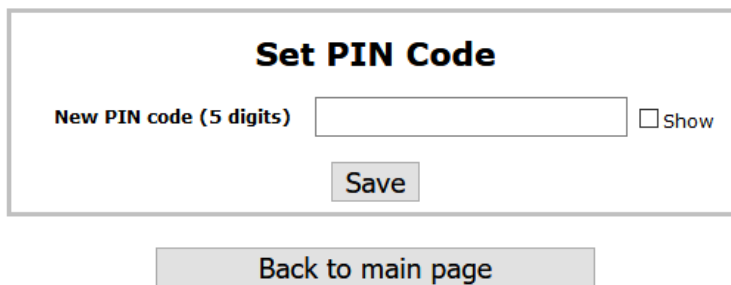

Set PIN Code

New PIN code (5 digits) Show

Save

Back to main page

Enter the desired new pin code, in the appropriate box, up to 5 numbers (**SHOW to display the PIN CODE**).

Press **SAVE** to save the pin. A POP UP window will confirm correct saving.

PIN CODE default setting: **00000**

Press **BACK to main page** to return to the main screen

TROUBLESHOOTING	CAUSES AND SOLUTIONS
The control unit does not switch on and the supply to terminals 40-42 is correct.	Check that: the connector is firmly inserted in its place, the connection wires are tight and that there are no obvious signs of burns on the connectors. Turn off the power supply and carry out the above instructions, restore the voltage.
CH4 is in FAULT for FOC (only the 3 Pt100 sensors are connected)	Programming error of the CH4 / YES control unit. <i>Check and repeat the programming on page 13-14 select CH4 /NO.</i>
One of the three/four channels is in FAULT for FOC/FCC	Check the connections of the Pt100 probes, check the indications provided in the paragraphs: <i>transport of measurement signals and thermometric probe diagnostics on page 16.</i>
When turned on, the indication "ECH" appears	A strong disturbance has damaged the memory data. See the paragraph for programmed data diagnostics on page 17.
All the Pt100 sensors are in FCC.	Incorrect sensor connection, the terminal block has been inserted upside down. <i>Check the connections and the terminal board.</i>
The temperature shown by one or more channels is wrong.	Contact the <i>TECSYSTEM</i> Technical Department.
Sudden trip of the main switch. The temperature is on standard levels. Just one channel has caused the trip.	Check the temperatures recorded in T-MAX, check the indications provided in the paragraphs: <i>transport of measurement signals and thermometric probe diagnostics on page 16. Activate the FCD function.</i>
FCD warning	See the FCD function on page 19.
During operation of the web server it is not possible to display the date and time and also the graphics screen does not work.	In the Access point mode select settings/Options and enter the date and time in the Set data/time (AP mode) box In Station mode, select settings/Networking and enter time.google.com in the Server NTP box
The web server has been set in Access Point mode but the network cannot be identified.	With the control unit off, keep the access point button pressed, then power the device and release the button after approximately 5 seconds. The <i>TECSYSTEM</i> network will appear and connect to the network using the <i>TECSYSTEM</i> password. Open your browser and type in the address 192.168.8.8 use the web server bar to enter the Settings page, press the Network setting button and check: the ACCESS POINT selection, the settings SSID and Password, press save.
The web server has been set in Station mode but the web server cannot be accessed.	With the aid of a device with a Wi-Fi connection (PC, Smartphone or Tablet) with the control unit off, keep the access point button pressed, then power the device, and release the key after approximately 5 seconds. Launch the search for the Wi-Fi network from your device. The <i>TECSYSTEM</i> network will appear, connect to the network using the <i>TECSYSTEM</i> password. Open your browser and type in the address 192.168.8.8, use the web server bar to enter the Settings, page, press the Network setting button and check: the STATION selection, the settings: IP – GATEWAY -SUBNET MASK – NET WORK SSID – PASSWORD, press save.
Contact the <i>TECSYSTEM</i> Technical Department if the problem persists.	

WARRANTY REGULATIONS

The purchased Product is covered by the manufacturer's or seller's warranty under the terms and conditions indicated in the "Tecsysteam s.r.l. General Sales Conditions", which can be consulted on the website www.tecsystem.it and/or in the stipulated purchase contract.

The warranty is considered valid only when the product is damaged by causes attributable to *TECSYSTEM* srl, such as manufacturing or components defects.

The warranty is invalid if the Product proves to have been tampered with/modified or incorrectly connected and causing voltages outside the set limits and does not comply with the technical data for use and assembly, as described in this instruction manual.

The warranty is always ex Corsico as stated in the "General Conditions of Sale".

EQUIPMENT DISPOSAL

The European directive 2012/19/EU (WEEE) has been approved to reduce the waste of electrical and electronic appliances and to encourage the recycling and reuse of materials and components of these appliances, thus reducing the disposal of harmful residues and compounds from electrical and electronic material.



All the electrical and electronic equipment supplied after 13 August 2005 is marked with this symbol, pursuant to European directive 2012/19/EU on electrical and electronic waste (WEEE). Any electrical or electronic equipment marked with this symbol must be disposed of separately from normal domestic waste.

Returning of used electrical appliances: contact TECSYSTEM or the TECSYSTEM agent to receive information on correct disposal of the appliances.

TECSYSTEM is aware of the impact its products have on the environment and asks its customers active support in the correct and environmentally-friendly disposal of its devices.

USEFUL CONTACTS

TECHNICAL INFORMATION : support@tecsystem.it

COMMERCIAL INFORMATION : info@tecsystem.it



FIRMWARE VERSION C01 T154-V WS

When the device is turned on, the writing T154 C01 appears, which means that: you have purchased the T154-V WS model.

What are the variations introduced in the T154-V WS model:

Default setting programming with values:

ALARM 120°C (CH1-2-3)
TRIP 135°C (CH1-2-3)
FAN YES (CH1-CH2-CH3)
FAN ON 90°C
FAN OFF 80°C
CH4 YES
ALARM 130°C (CH4)
TRIP 145°C (CH4)
HFN NO
FCD NO
VOT YES
FLS ALARM NO
FLS TRIP NO
FLS FAULT YES

Information on the VOTING function (VOT) on page 16.

UL SPECIFICATION AND RATINGS

CABLE SPECIFICATION	Dimension for main circuit 18AWG, working temperature over 105°C
MASS OF THE EQUIPMENT	0,48 Kg
INPUT SUPPLY	24 – 240 Vac /Vdc ($\pm 10\%$), 50/60 Hz, 7,5VA max
PROTECTION	External switch or circuit breaker
OUTPUTS RELAYS	4 relay Output: 10A 250Vac-res COS=1
OPTIONAL PORTS	Wi-Fi
Suitable for use on a flat surface of a type 1 enclosure if back panel is provided with two short fixing screws tightening torque: 0.57Nm	