

# INSTRUCTION MANUAL

## NT935BH ETH

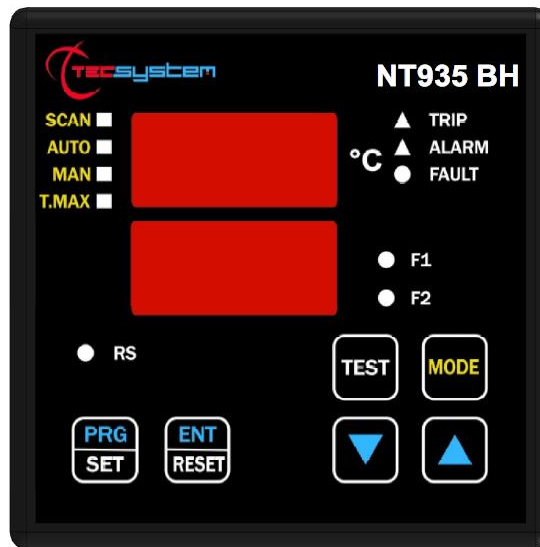

1MN0191 REV. 0



operates with ISO9001 certified quality system

**TECSYSTEM S.r.l.**  
20094 Corsico (MI)  
Tel.: +39-024581861  
Fax: +39-0248600783

<http://www.tecsystem.it>

R. 1.3 16/05/23

ENGLISH

“Translations of the original instructions”

## INTRODUCTION

First of all we wish to thank you for choosing to use a **TECSYSTEM** product and we strongly suggest that you read this instruction manual carefully: You will understand the use of the equipment and therefore be able to take advantage of all its functions.

ATTENTION! THIS MANUAL IS VALID AND COMPLETE FOR THE NT935BH ETH MODEL CONTROL UNIT.

## TABLE OF CONTENTS

|  | PAGE |
|--|------|
| 1) SAFETY REQUIREMENTS .....             | 4    |
| 2) ACCESSORIES .....                     | 5    |
| 3) TECHNICAL SPECIFICATIONS .....        | 6    |
| 4) FRONT PANEL .....                     | 8    |
| • DISPLAY .....                          | 9    |
| • OPERATING PROGRAM CONTROL .....        | —    |
| • NOTES ON SCAN AND MAN FUNCTIONS .....  | —    |
| • LED TEST .....                         | —    |
| • ALARM RELAY TEST .....                 | —    |
| • ALARM RELAY SILENCING .....            | —    |
| 5) ASSEMBLY .....                        | 10   |
| 6) ELECTRICAL CONNECTIONS .....          | 11   |
| • NT935 ETH BACK .....                   | —    |
| • POWER SUPPLY .....                     | 12   |
| • ALARMS AND VENTILATION .....           | —    |
| • FAULT AND RESET MESSAGE SEQUENCE ..... | —    |
| 7) PROGRAMMING .....                     | 13   |
| • NT935BH ETH .....                      | —    |
| • PROGRAMMING NOTES .....                | 14   |
| • TEMPERATURE SENSORS .....              | 15   |
| • MEASUREMENT SIGNAL TRANSFER .....      | —    |
| • TEMPERATURE SENSOR DIAGNOSTICS .....   | 16   |
| • VOTING FUNCTION .....                  | —    |
| • PROGRAMMED DATA DIAGNOSTICS .....      | —    |
| • TEMPERATURE DIAGNOSTICS .....          | —    |
| • COOLING FAN CONTROL .....              | 17   |
| • TRBH FANS DIAGNOSTICS .....            | 18   |
| • FAN TEST .....                         | —    |

|  | PAGE |
|--|------|
| 8) OUTPUT ETHERNET MODBUS TCP .....                      | 18   |
| • INTRODUCTION TO THE ETHERNET MODULE .....              | —    |
| • OPERATING NOTES .....                                  | —    |
| • DATA TRANSMISSION .....                                | —    |
| • NOTES ON ETHERNET ELECTRICAL CONNECTIONS .....         | —    |
| • FUNCTION CODE .....                                    | 19   |
| • CODE 3(10). .....                                      | —    |
| • CODE 16(10). .....                                     | —    |
| • NOTES FOR REMOTE PROGRAMMING .....                     | —    |
| • ERROR CODES .....                                      | —    |
| • UNACCEPTABLE DATA .....                                | 20   |
| • ILLEGAL DATA .....                                     | —    |
| • MODBUS MAPPING TABLE .....                             | —    |
| 9) FAILSAFE FUNCTION .....                               | 25   |
| 10) ETHERNET MODULE PARAMETER PROGRAMMING .....          | 26   |
| • ETH0 CONNECTIONS .....                                 | —    |
| • TELNET ENABLING .....                                  | 27   |
| • TELNET SCREEN .....                                    | —    |
| • IP PARAMETER PROGRAMMING MENU .....                    | 28   |
| 11) Pt100 EXTENSION CABLE TECHNICAL SPECIFICATIONS ..... | 30   |
| 12) FCD FUNCTION .....                                   | 31   |
| 13) WARRANTY REGULATIONS .....                           | —    |
| 14) TROUBLESHOOTING .....                                | 32   |
| 15) EQUIPMENT DISPOSAL .....                             | 33   |
| 16) USEFUL CONTACTS .....                                | —    |

## SAFETY REGULATIONS



### ATTENTION:

Read the manual carefully before starting to use the control unit. Keep the instructions for future reference.



Do not open the device, touching any internal components can cause electric shock. Contact with a voltage over 50 Volts can be fatal. To reduce the risk of electric shock, do not dismantle the back of the device for any reason. Moreover its opening would void the warranty.

**Before connecting the device to the power supply, make sure that all the connections are correct.** Always disconnect the unit from the supply before any cabling modification.



Any work on the equipment must be entrusted to a qualified engineer.

**Failure to comply with these instructions can cause damages, fires or electric shock, and possible serious injuries!**

### POWER SUPPLY

The NT935BH ETH can be supplied by 85 to 260 Vac-Vdc, irrespectively of polarity in Vdc. Before using it, make sure the power cable is not damaged, knotted or pinched. Do not tamper with the power cable. Never disconnect the unit by pulling the cable, avoid touching the pins. Do not carry out any operations of connecting/disconnecting with wet hands. To disconnect the device, do not use objects such as levers. Disconnect the power supply immediately if you notice that the device gives off a burning smell or smoke: contact the assistance.

### LIQUIDS

Do not expose the equipment to splashes or drops, do not position it in places with humidity exceeding 90% and never touch with wet or damp hands. If any liquid penetrates the control unit, disconnect it immediately and contact technical service.

### CLEANING

Disconnect the power cable before cleaning the control unit, use a dry cloth to dust it, without any solvent or detergents, and compressed air.

### OBJECTS

Never insert any objects into the cracks of the control unit. If this happens, disconnect the control unit and contact an engineer.

### USE RESERVED TO QUALIFIED PERSONNEL

The purchased goods are a sophisticated electronic device that is totally unsuitable to be used by non-qualified personnel. Any work must be carried out by a specialist engineer.

### ACCESSORIES

The use of non-original accessories or spare parts can damage the unit and endanger users' safety. In the event of faults, contact technical service.

### POSITIONING

Install the control unit indoors, in a place protected from water splashes and from the sun's rays. Do not place near heat sources exceeding the parameters stated in this manual. Position on a stable surface, far from any possible vibrations. Position the unit as far as possible from any intense magnetic fields.

### REPAIRS

Do not open the control unit. For any fault, always use qualified personnel. The opening of the control unit and/or the removal of the series identifying label entails the automatic forfeiture of the warranty. The Warranty seal is applied to all devices, any attempt to open the unit would break the seal and cause the consequent automatic forfeiture of the warranty.

### FUNCTIONS

**To control the transformer correctly from a temperature point of view, enabling the VOTING function is allowed where the load distributed between the phases of the transformer is adequately balanced.**

### TECHNICAL INFORMATION

Mail: [ufficiotecnico@tecsystem.it](mailto:ufficiotecnico@tecsystem.it) — tel: 02/4581861

## ACCESSORIES

The following objects are present inside the box:

Control unit



Start guide and QR code



2 blocks for panel fixing

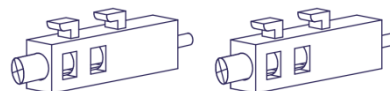

1 Terminal 3 pitch poles 5 supply  
Code: 2PL0367 - Screws tightening torque 0.5Nm



1 relay terminal 12 poles pitch 5  
Code: 2PL0361 - Screw tightening torque 0.5Nm



1 Terminal 12 poles pitch 3.81 sensors Pt100  
Code: 2PL0420 - Screw tightening torque 0.25Nm



1 Terminal 4 pitch poles 3.81 for BLDC output  
Code: 2PL0368 - Screws tightening torque 0.25Nm



**ATTENTION: always install the device using the terminals included in the pack.  
The use of terminals other than those included with the control unit might cause malfunctions.**

| <b>TECHNICAL SPECIFICATIONS</b>   | <b>NT935BH ETH</b>        |
|---|---------------------------|
| <b>POWER SUPPLY</b>   |                           |
| Supply rated values   | 85-260 Vac-Vdc<br>50/60HZ |
| Vdc with invertible polarities  | •                         |
| <b>INPUTS</b>   |                           |
| 4 inputs for three-wire Pt100 RTD sensors (max section 1.5mm <sup>2</sup> )   | •                         |
| Connections on removable terminal boards  | •                         |
| Input channels protected against electromagnetic interference   | •                         |
| Thermoresistances cable compensations   | 500m (1mm <sup>2</sup> )  |
| <b>OUTPUTS</b>  |                           |
| 2 alarm relays (ALARM AND TRIP) SPDT  | •                         |
| 1 sensor or operating failure (FAULT) relay SPST  | •                         |
| Output relays with 10A-250Vac-res COS $\Phi$ =1 contacts.   | •                         |
| 1 ventilation management relay SPST FAN 2   | •                         |
| Ethernet output 10Base T/100Base-TX Modbus TCP slave.   | •                         |
| TRBH output controls FANS   | •                         |
| <b>DIMENSIONS</b>   |                           |
| 100x100 mm– din43700-prof .131mm (including terminal block)   | Hole 92 x 92 mm           |
| <b>TESTS AND PERFORMANCE</b>  |                           |
| Construction in compliance with CE regulations  | •                         |
| Protection from electrical interference EN 61000-4-4  | •                         |
| Dielectric strength 1500 Vac for a min. between output relays and sensors, relay and power supply, power supply and sensors | •                         |
| Accuracy $\pm$ 1% full scale value, $\pm$ 1 digit   | •                         |
| Ambient operating temperature from –20°C to +60°C   | •                         |
| Humidity 90% non-condensing   | •                         |
| Polycarbonate frontal film IP65   | •                         |

## TECHNICAL SPECIFICATIONS

NT935BH ETH

NORYL 94 \_V0 housing

•

Absorption 7.5VA

•

Digital linearity of sensor signal

•

Self-diagnostic circuit

•

Protection treatment of the electronic part

Optional

## DISPLAY AND DATA MANAGEMENT

2 x 13 mm displays with 3 digits to display temperatures, messages and channels

•

3 LEDs to display the state of the alarms of the selected channel (ALARM-TRIP-FAULT)

•

4 leds selection of display mode (SCAN-AUTO-MAN-T-MAX)

•

2 LEDs to display the state of FAN1 and FAN2

•

Temperature control from 0°C to 240°C (\*)

•

2 alarm thresholds for channels 1-2-3

•

2 alarm thresholds for channel 4

•

1 activation threshold FAN1 ON TRBH

•

1 activation threshold FAN2 ON TRBH/RELAY

•

FAN1 TRBH fan speed adjustment 10 steps

•

Sensor diagnostics (Fcc-Foc-Fcd)

•

Data memory diagnostics (Ech)

•

Fan fault diagnostics (RS1-RS2-RSE- EST-B1-B2-B1.2)

•

Access to programming through front keyboard

•

Automatic exit from programming, display and relay test after 1 minute of inactivity

•

Incorrect programming warning

•

Selection between channels automatic scanning, hottest channel or manual scanning

•

Storage of maximum temperatures reached by channels and alarm status

•

Front key to reset the alarms

•

Voting Function

•

Fail Safe Function

•

(\*) On request, reading version -40°C to 200°C with alarm temperature control from 0°C to 200°C

# FRONT PANEL

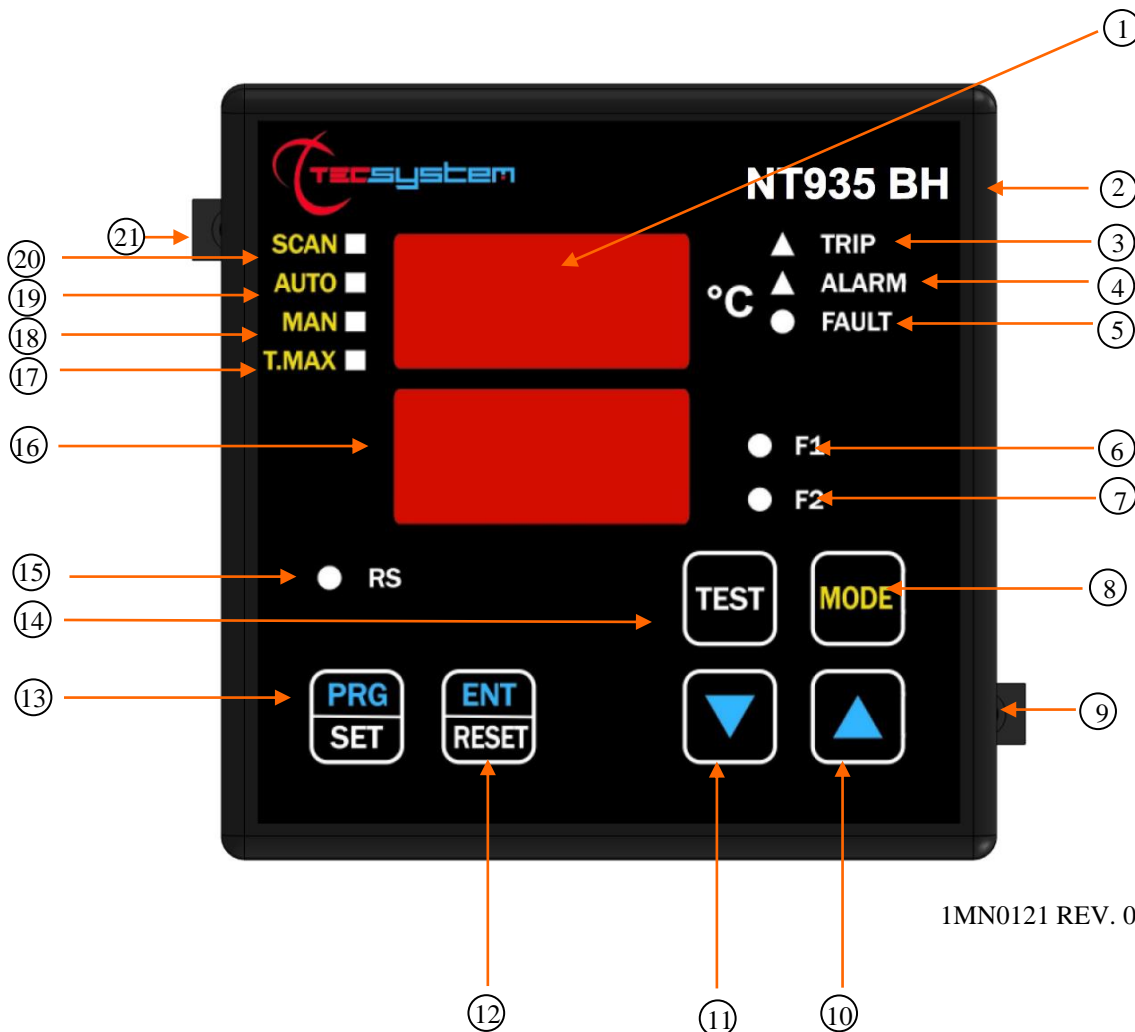

1MN0121 REV. 0

|     |                                    |     |                                  |
|-----|------------------------------------|-----|----------------------------------|
| 1)  | 3-digit temperature display        | 12) | Enter/Reset button               |
| 2)  | Control unit series                | 13) | Programming/Setting key          |
| 3)  | TRIP (red) LED                     | 14) | Led/relay test key               |
| 4)  | ALARM (yellow) LED                 | 15) | RS (green) LED                   |
| 5)  | FAULT (red) LED                    | 16) | 3-digit channel display          |
| 6)  | FAN 1 TRBH signalling (yellow) LED | 17) | T-max mode selection (red) LED   |
| 7)  | FAN 2 TRBH / RELAY (yellow) LED    | 18) | Man mode selection (yellow) LED  |
| 8)  | Display mode selection key         | 19) | Auto mode selection (green) LED  |
| 9)  | Fixing blocks                      | 20) | Scan mode selection (yellow) LED |
| 10) | UP key                             | 21) | Fixing blocks                    |
| 11) | DOWN key                           |     |                                  |

## DISPLAY

**The first display is dedicated to temperatures.**

**The second display to the monitored channel.**

When the device is switched on or after a reset, the model of the control unit, the type of sensors, VER "00" (firmware version), the temperature range of the device and the identification abbreviation are always shown on the display. Pressing the MODE key, the display modes can be set:

- **SCAN:** the control unit shows in scanning (every 2 seconds) all the enabled (°C) and disabled (NO) channels.
- **AUTO:** the control unit displays the hottest channel automatically.
- **MAN:** manual reading of the channel temperature using the up/down keys ▲▼
- **T.MAX:** The display shows the maximum temperature of the channel selected with the cursor keys. In the event of a fault, the Tmax value is replaced with the type of fault stored (fcc-foc). Turning on the Trip Alarm-Fault LED warns of any events that have occurred. The recordings are always successive to the moment in which the T.Max is reset (by pressing RESET).

## OPERATING PROGRAM CONTROL

To control the protection levels programmed, press the PRG key twice to access the **VIS** programme. Repeatedly pressing the PRG key, you can scroll through all the previously loaded values in sequence. After 1 minute's keyboard inactivity, the programming display procedure is automatically abandoned.

To stop the display, press the ENT key.

## SCAN AND MAN FUNCTION NOTES

During the SCAN and MAN modes, the operation of the NT935 can be displayed.

### 1) RUN CPU:

This message appears upon ignition of the device.

### 2) Ech Err:

This message appears when damage in the EEPROM memory is detected.

Pressing Reset will cancel the message and restore the original default parameters, listed in the programming paragraph on pages 13-14. Return the control unit to TECSYSTEM for repairs.

### 3) CAL Err:

This message appears when damage is found in the measurement circuit.

The temperature values displayed might be incorrect. Return the control unit to TECSYSTEM for repairs.

### 4) Pt Err:

This message appears when it is detected that one or more PT100 sensors are not working correctly, FOC, FCC and FCD indications in the temperature sensor diagnostics paragraph on page 16.

### 5) BH Err:

This message appears when damage is found in the measurement circuit.

**FLT RS1 or RSE:** communication failure with the B1 control box or extractor control box (RSE)

**FLT RS2:** communication failure with the B2 control box

**FLT B1 or EST:** failure of at least one motor on the B1 bar or of an extractor (EST)

**FLT B2:** failure of at least one motor on the bar B2

**FLT B1-B2:** failure of at least one motor on the B1 bar and B2 bar

The above messages will be displayed following the 1-2-3-4-5 priority stated.

In case of **Err** the FAULT relay will be de-energised.

**NOTE:** in any display mode in the event of a fault, the control unit will automatically set itself in **SCAN mode (PRIVILEGED SCAN)** thus allowing the immediate display of the fault condition on the relevant **CH** channel or on the fans (the **Mode** button will be disabled).

## LED TEST

We suggest carrying out the control unit LED test regularly.

For this operation, press the TEST key briefly; all the displays turn on for 2 seconds.

**If one of the LEDS does not work, please return the control unit to TECSYSTEM for repair.**

## ALARM RELAY TEST

This function allows you to carry out a test of the relay operation without having to use further devices. To start the test procedure, press and hold the TEST button for approximately 5 seconds: the TST indication appears for 2 seconds confirming entry into the Relays Test mode.

The LED that is lit shows the relay to be tested; use the cursors ▲▼ to select the desired relay.

Press the SET and RESET keys to energise and de-energise the relay to be tested; the display will show ON-OFF.

After 1 minute's keyboard inactivity, the RELAY TEST procedure will be automatically abandoned.

To stop the RELAY TEST procedure, press the TEST key.

Alternatively it is possible to use the PT100 model simulator: SIM PT100.

**ATTENTION: accessing at the relay test mode will temporarily disable the failsafe function, the relays with function enabled switch (ALARM-TRIP-FAULT).**

## ALARM RELAY SILENCING

To silence the ALARM signal, press the RESET key: the relay will de-energise and the ALARM LED, which is on steady will start to flash. Silencing is automatically disabled when the temperature goes below the ALARM threshold.

## ASSEMBLY

Drill a hole in the panel sheet with dimensions of 92 x 92 mm.

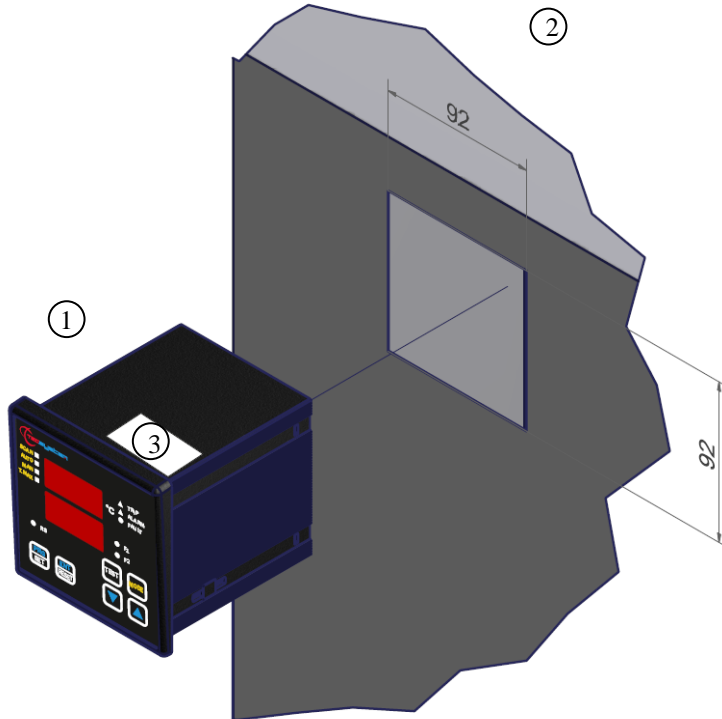

1MN0007 REV. 0

|    |                      |    |   |
|----|----------------------|----|---|
| 1) | Control unit         | 2) | Panel hole dimensions (+0.8 mm tolerance) |
| 3) | Identification label |    |   |

Secure the appliance firmly by means of the supplied fixing blocks.

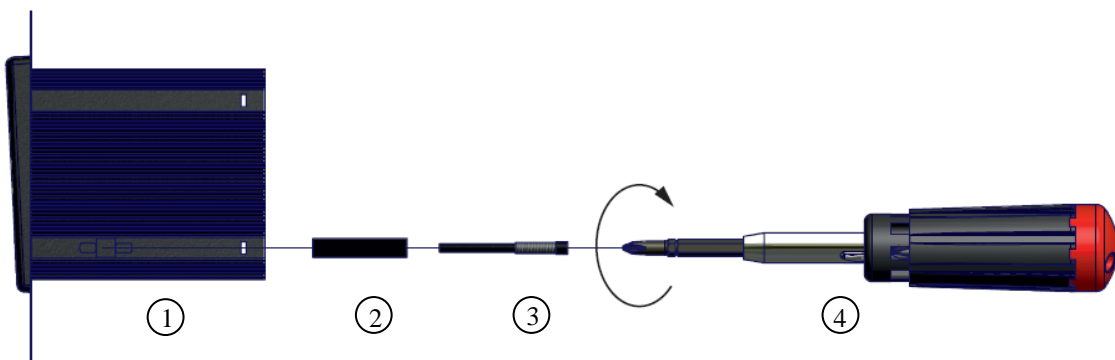

1MN0008 REV. 0

|    |               |    |                                 |
|----|---------------|----|---------------------------------|
| 1) | Control unit  | 3) | Locking screws                  |
| 2) | Fixing blocks | 4) | Cross-head screwdriver #1X100mm |

# ELECTRICAL CONNECTIONS



NOTE: all the useful information on the TRBH system's electrical connections is available in the TRBH SYSTEM manual.

NT935BH ETH

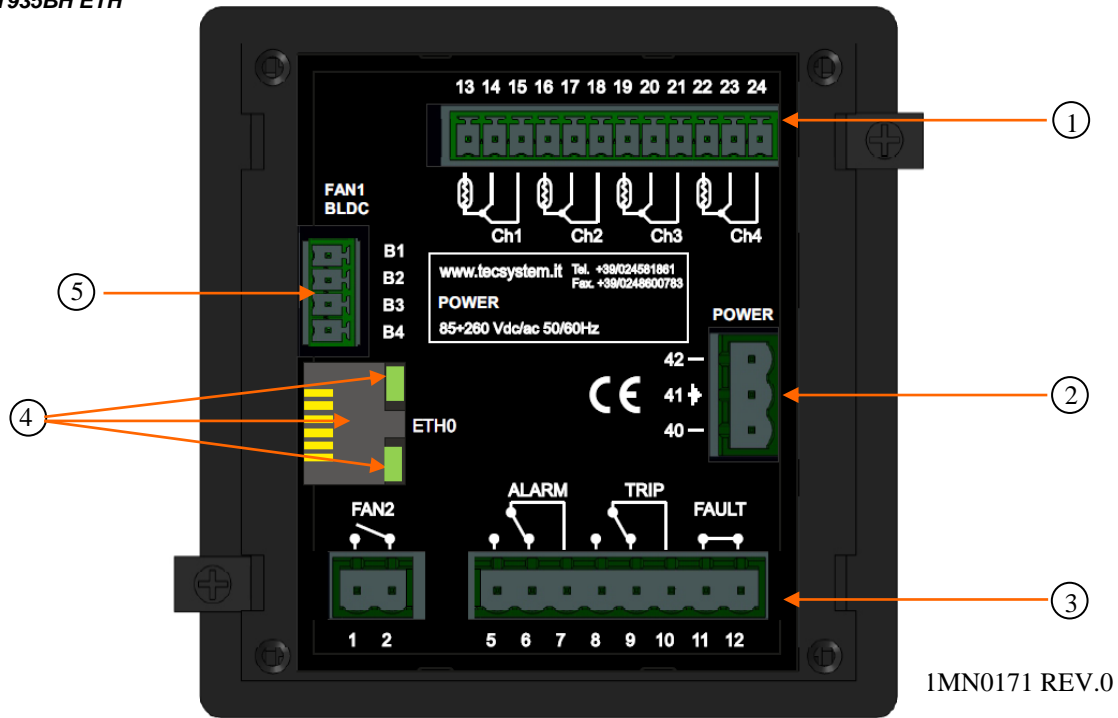

1MN0171 REV.0

|                                       |  |
|---------------------------------------|--|
| 1) Pt100 sensors (white-red-red)      | 4) RJ45 Ethernet output, Link-Activity led, see indication on page 30.               |
| 2) Power supply 85-260Vac-cc 50/60Hz. | 5) FAN1 BLDC output (parallel connection of control box B1 or control box extractor) |
| 3) Relays (FAN2-ALARM-TRIP-FAULT)     |  |

Note: image relay contacts in non-alarm condition, except for the FAULT relay which switches: contacts 11-12 open (NO) contacts 11-12 closed (NC) fault condition identification. Read paragraph Alarms p. 12 and see image of fault contact switching.

## RELAYS CONNECTION EXAMPLE

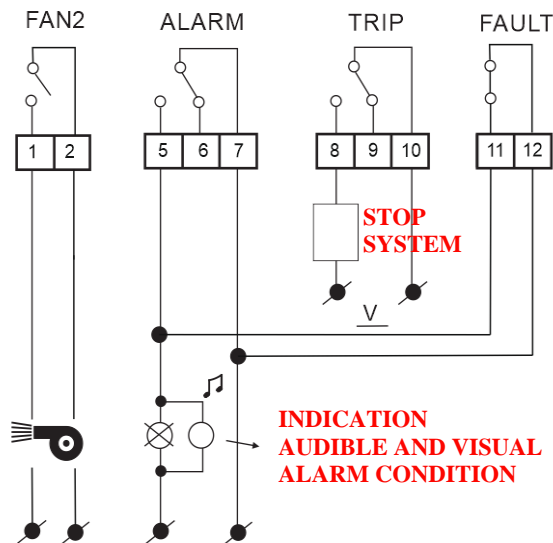

Output relay with contacts of 10A-250Vac-res COS $\Phi$ =1.

1MN0095 REV. 0

## Pt100 CONNECTION EXAMPLE

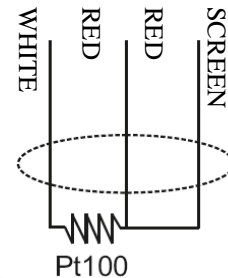

Note: before connecting the probes to the control unit, carefully read the paragraph measurement signal transfer on page 15.

## POWER SUPPLY

The NT935BH ETH can be supplied by 85 to 260 Vac-Vdc, 50/60 Hz irrespectively of polarity in Vdc (terminals 40-42). This particularity is obtained thanks to the use of a tested power supply, of new conception and realisation, which frees the installer from any uncertainty regarding the correct Vac or Vdc power supply.

The earthing cable must always be connected to terminal 41.

When the control unit is powered directly by the secondary of the transformer to be protected, it can be burnt out by high intensity overvoltages.

These problems occur if the main switch is closed and the transformer does not have the load (no load test).

The above is much more evident when the 220 Vac voltage is taken directly from the bars of the secondary of the transformer and there is a fixed capacitor battery for power factor correction of the transformer itself.

To protect the control unit against line overvoltages, the PT-73-220 electronic arrester, designed by TECSYSTEM S.r.l. for this specific purpose, is recommended. Alternatively, it is advisable to use 110 V AC supply voltages or, even better, 110 VDC.

If an existing control unit must be replaced with a new one, to guarantee its correct and safe operation, the sensor/relay/supply connecting terminals must be replaced with the new terminals supplied.

## ALARMS AND VENTILATION

Carry out the electrical connections on the removable terminal blocks only after disconnecting them from the unit.

When the control unit is in one of the following modes, it does not perform any thermal monitoring, moreover the relays will all be disabled, the fault contact switches and the fault LED will flash.

- Vis. Programming display.
- PRG programming.
- Relay test.

The ALARM and TRIP relays only switch when the set temperature thresholds are exceeded.

The FAULT (fault) contact, programmed in active failsafe mode (default YES), opens (11-12) when the appliance is powered, only if during the access phase the control unit does not detect anomalies, and keeps the switching until when one of the following events occurs:

- Data memory fault (Ech message).
- Pt100 sensor fault (FCC short-circuited sensor, FOC interrupted sensor or Fcd quick temperature increase)
- CAL damage to the measurement circuit.
- Insufficient supply voltage.
- During the power on reset after programming (PRG), displaying the data (VIS) and relay test.
- Fan fault signalling (RS1-RSE-RS2-B1-B2-B1.2 EST)

The FAULT failsafe mode can be disabled FAULT failsafe "NO" see programming step 34-35 page 14.

NOTE: in order to avoid unwanted system outages, do not connect the FAULT relay to the transformer tripping circuit.

### FAULT CONTACT (failsafe active)

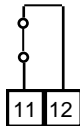

FAULT 11-12 NC: ALARM FAULT OR POWER OFF

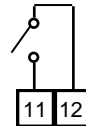

FAULT 11-12 NO: POWER ON OR NO FAULT

The FAN1 and FAN2 contacts can be used to control the cooling fans, or they can be inserted in the conditioning system of the transformer room, see paragraph cooling fan control on page 17.

NOTE: always disconnect the unit before performing any electrical connections.

### FAULT AND RESET MESSAGE SEQUENCE



























Find below the sequence of fault messages and RESET function condition.

- |           |                            |                          |
|-----------|----------------------------|--------------------------|
| 1) ECH    | eeprom fault               | erasable message         |
| 2) CAL    | measurement circuit fault  | erasable message         |
| 3) FCD    | quick temp. increase fault | resettable condition     |
| 4) ERR PT | FCC or FOC sensor fault    | non-resettable condition |
| 5) BH ERR | fan failure                | non-resettable condition |

# PROGRAMMING

## NT935BH ETH

| STEP | PRESS   | EFFECT  | PRESS  | NOTES   |
|------|---|---|--|---|
| 1    |    | Press and hold the PRG button until the display shows SET PRG                                     |  |  |
| 2    |   | Select PRG SET to proceed with programming or PRG 1 to load the default values                    |       | PRG 1 default data  |
| 3    |    | The ALARM threshold for (CH 1-2-3) is displayed. Set the desired threshold, the Alarm LED flashes |  | Default 90°C  |
| 4    |    | The TRIP threshold for (CH 1-2-3) appears and the Trip LED flashes.                               |       |   |
| 5    |   | Set the desired threshold   |  | Default 119°C   |
| 6    |    | The display shows FAN 1 TRBH (CH 1-2-3) the led Fan1 flashes.                                     |       | Default YES   |
| 7    |   | Select YES/NO   |  |   |
| 8    |   | The display shows (CH4) Enabling CH4  |     |   |
| 9    |   | Select YES or NO  |   | With YES the CH4 is enabled<br>with NO the CH4 is disabled                          |
| 10   |  | The ALARM threshold for (CH4) appears and the Alarm LED flashes.                                  |  | If CH4=NO jump to step 16, Default NO   |
| 11   |   | Set the desired threshold   |   | Default 120°C   |
| 12   |  | The TRIP threshold for (CH4) is displayed. The TRIP led flashes                                   |  |   |
| 13   |   | Set the desired threshold   |   | Default 140°C   |
| 14   |  | The display shows FAN 2 for (CH4)   |  | Default Yes   |
| 15   |   | Select YES/NO   |   |   |
| 16   |  | B-M is displayed<br>The FAN1 led flashes  |  | Default B2-M3   |
| 17   |   | Select the desired TRBH configuration, TRBH notes on page 17                                      |   | TRBH :<br>B0-M0    B1-M3<br>B1-M1    B2-M1<br>B1-M2    B2-M2<br>B2-M3               |
| 18   |  | The display shows ON (CH 1-2-3), the FAN1 led   |  | Default 60°C  |
| 19   |   | Set the desired threshold FAN1 ON   |   |   |

|    |   |   |  |   |
|----|---|---|--|---|
| 20 |    | EST is displayed<br>The FAN2 led flashes  |  | Default n-0   |
| 21 |   | Select the desired TRBH EXTRACTOR configuration<br><b>TRBH notes on page 17</b> |       | TRBH EXTRACTOR:<br>n_0<br>n_1<br>n_2<br>n_3                   |
| 22 |    | The display shows ON (CH4)<br>the FAN 2 LED flashes                             |  | Default 45°C  |
| 23 |   | Set the desired threshold FAN2 ON   |       | If FAN 2 NO is selected skip to step 24                       |
| 24 |    | HFN (NO) is displayed<br>The FAN1-FAN2 LEDs flash                               |  | Fan cyclic test<br>for 5 min. every "n" hours                 |
| 25 |   | Set the desired number of hours   |       | Default NO = function<br>disabled                             |
| 26 |    | FCD (NO) is displayed   |  | Fault for quick temperature<br>of the temperature (°C/sec)    |
| 27 |   | Set the desired value<br>(FCD info on page 31)                                  |       | Default NO<br>(function excluded)                             |
| 28 |    | VOT (NO) is displayed<br>(VOTING info on page 16)                               |  |   |
| 29 |   | Select YES or NO  |       | Default NO<br>(function excluded)                             |
| 30 |    | FLS (ALARM) is displayed<br>Blinking ALARM LED<br>(FAIL SAFE info on page 25)   |  |   |
| 31 |   | Select YES or NO  |     | Default NO  |
| 32 |  | FLS (TRIP) is displayed<br>Blinking TRIP LED                                    |  |   |
| 33 |   | Select YES or NO  |   | Default NO  |
| 34 |  | FLS (FAULT) is displayed<br>Blinking FAULT LED                                  |  |   |
| 35 |   | Select YES or NO  |   | Default YES   |
| 35 |  | END is displayed  |  | End of programming  |
| 36 |  | Press ENT to save the set data<br>and exit programming                          |  | incorrect programming of the LED<br>values indicated (note 6) |
| 37 |  | Return to step 1  |  |   |

### PROGRAMMING NOTES

- 1) The MODE key allows reversing the programming steps according to the sequence 28-26-8-1
- 2) The TEST key allows exiting programming without saving the modified data.
- 3) After 1 minute's keyboard inactivity programming is abandoned without saving the data.
- 4) During programming the control unit does not control/protect the monitored machine.
- 5) At the end of programming the control unit is restarted and the FAULT relay is disabled until the unit is fully restarted.
- 6) If pressing ENT, "Err" appears, it means that one of the following mistakes has been made:

ERR ALL. = ALARM ≥ TRIP

The device automatically prepares itself for the programming step of the error committed

**NOTE: EVERY TIME THE CONTROL UNIT PROGRAMMING, WITH CONFIRMATION OF DATA SAVING, THE VALUES STORED IN T-MAX ARE RESET AT THE TIME OF STORING.**



## ATTENTION:

We recommend you check the device's programming before starting the device.

The default parameters set by TECSYSTEM might not match your requirements.

Programming the device is the end user's responsibility, the settings of the alarm thresholds and the enabling of the functions described in this manual must be checked (by a specialized engineer) according to the application and features of the system the control unit is installed on.

### TEMPERATURE SENSORS

Each Pt100 thermometric sensor has a white conductor and two red ones (CEI 75.8 standards).

The CH2 channel must always refer to the central column of the transformer.

The CH4 channel must refer either to the transformer core, or to the Pt100 room sensor whenever it is necessary to thermostat the transformer room using the NT935 ETH control unit.

### MEASUREMENT SIGNAL TRANSFER

All the Pt100 measurement signal transfer cables must strictly comply with the following rules:

1. Every Pt100 must be connected with a three-wire cable with a minimum section of 0.35mm<sup>2</sup> and a maximum of 1 mm<sup>2</sup>.
2. The extension cable must be screened with tinned copper braid with an 80% cover
3. Conductors must be twisted, maximum recommended step 60mm
4. The cable screening must only be earthed with a termination, preferably on the control unit side.
5. The sensors' signal transfer cable must not be near electrical cables, either low or medium-high voltage.
6. The Pt100 cable and the signal transfer cable must be laid in a straight line, without any winding.
7. Any caps used to butt conductors must be crimped properly to avoid false contacts.

**NOTE: to install the sensors and signal transferring cable correctly, read the SCS/PT100 SENSORS installation note manual.**

**What may happen when installation rules are not complied with.**

1) The electrical field propagating from the power line of another circuit couples capacitively with the conductors (in particular with unscreened cables). The effect of this coupling creates a signal that overlaps the signal transmitted by the nearby conductors, causing incorrect readings.

2) The variations in magnetic flux in the power lines may induce an electromotive force on the signal transferring cables (in particular non-twisted cables), that, being a closed circuit, generates a current. This interference current, multiplied by the circuit resistance, gives a voltage value that overlaps the signal to be transmitted, distorting the sensor measurement.

3) False contacts can alter the signal with the consequent variation in the temperature detected.

In specific cases, when the rules for connecting the Pt100 sensors are not complied with, the following anomalies can occur between the SCS box and the temperature control unit:

- a) incorrect temperature readings, alarms or anomalous tripping
- b) mechanical/electrical fault of the Pt100 sensors
- c) damage to the Pt100 inputs of the control unit.

TECSYSTEM S.r.l. has designed its own special cable to transfer the measurement signals, CEI-compliant, with all the protection requirements provided for mod. CT-ES

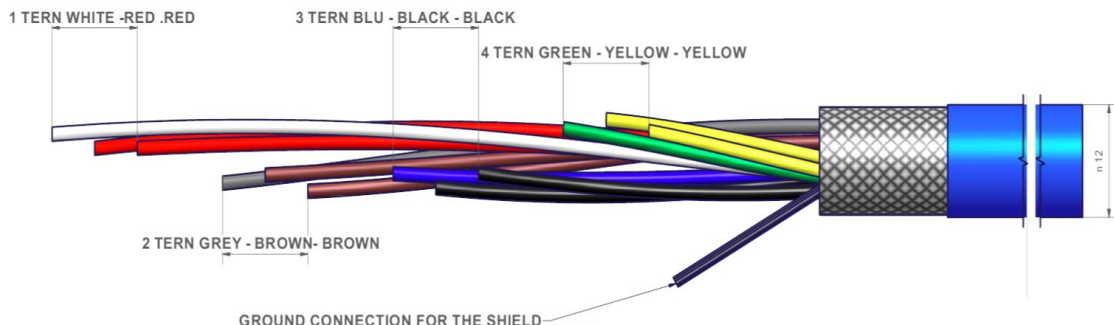

**NOTE: the use of cables not complying with the above could cause possible reading anomalies. It is always important to take into account that any interference on the signal lines might cause anomalies on the Pt100 inputs (CH1-CH2-CH3-CH4) or on the sensors themselves.**

All "NT" series control units have linearity of the sensor signal, with a maximum error of 1% of full scale value.

### TEMPERATURE SENSOR DIAGNOSTICS

In case of failure or exceeded full scale value of one of the thermometric sensors installed on the machine to be protected, the FAULT relay opens immediately with the relative warning of faulty sensor on the corresponding channel.

Fcc indicates sensor in short circuit or exceeding the minimum full scale value of the control unit  $-8^{\circ}\text{C}$  (for version  $0^{\circ} \div 240^{\circ}\text{C}$ ) and  $-48^{\circ}\text{C}$  (for version  $-40^{\circ}\text{C} \div 200^{\circ}\text{C}$ )

Foc indicates sensor interrupted or exceeding the maximum full scale value of the control unit  $243^{\circ}\text{C}$  (for version  $0^{\circ} \div 240^{\circ}\text{C}$ ) and  $203^{\circ}\text{C}$  (for version  $-40^{\circ}\text{C} \div 200^{\circ}\text{C}$ )

To eliminate the message and to restore the Fault contact opening, check the connections of the Pt100 and replace the faulty sensor if necessary. In case the minimum/maximum full scale value has been reached, make sure that the environmental conditions correspond to what is indicated by the control unit.

Note: exceeding the minimum/maximum full scale can also be caused by possible disturbances on the sensor lines, in this case the following are recommended:

Check correct installation of the sensors and especially of the extension cable (as indicated in the paragraph MEASUREMENT SIGNALS TRANSFER).

Activation of the functions: VOTING (shown below) or FCD (on page 31) in relation to the system conditions.

CAL message display: the indication appears when the measurement circuit is damaged. The temperature values displayed might be incorrect. Return the control unit to TECSYSTEM for repairs.

### VOTING FUNCTION

The voting function derives from the redundancy concept that consists in duplicating the components of a system to increase their **reliability**.

#### How does VOTING work?

Using the redundancy principle, we use the sensors installed on the three phases U-V-W to monitor the transformer's operation, and at the same time to ascertain the sensors are working correctly, discriminating against any false alarms (generated by installation errors).

By activating the **VOTING "YES"** function, the control unit compares the temperature values recorded on the monitored CH1-CH2-CH3 channels and enables the switching of the (**TRIP**) disconnect contact only if the **TRIP** threshold has been exceeded on at least two channels over the same period T.

By selecting **VOTING "NO"** the function will be disabled.

Note: if Voting "Yes" is programmed, the switching of the **ALARM** contact will signal exceeding of the alarm threshold on each individual channel.

To enable the Voting function, read the programming section on pages 13-14.



**Attention: To control the transformer correctly from a temperature point of view, enabling the VOTING function is allowed where the load distributed between the phases of the transformer is adequately balanced. In addition, any conditions of FAULT: FCC-FCC-FCD on two or more channels, with active voting, can determine the TRIP contact inhibition.**

### PROGRAMMED DATA DIAGNOSTICS

In case of failure of the internal memory or corruption of programmed data, just after switching on, **Ech** appears with the relevant Fault contact signal.

In this case, for safety reasons, the default parameters are loaded automatically (see programming table on pages 13-14).

Eliminate the **Ech** indication by pressing RESET and run programming to enter the desired values.

Finally switch the unit off and back on to check the memory works correctly, if it is damaged **Ech** will be displayed again (send the control unit to TECSYSTEM srl for repairs).

### TEMPERATURE DIAGNOSTICS

When one of the thermometers detects a temperature higher than  $1^{\circ}\text{C}$  with respect to the pre-set value as the alarm limit, after approximately 5 seconds the **ALARM** relay switches and the channel **ALARM LED (CHn)** switches on.

When the trip temperature limit is exceeded, after approximately 5 seconds the **TRIP** relay switches and the channel **TRIP LED (CHn)** switches on.

As soon as the recorded temperature returns to values equal to or lower than the limit set for the **ALARM** and **TRIP** relays switching, these relays de-energise and the corresponding LEDs switch off.

The values of **ALARM** and **TRIP** are kept in the internal memories: they can be recalled by entering the Vis modes (displaying programmed parameters) and modifiable in the PRG mode (programming).

## COOLING FAN CONTROL

The NT935BH control unit, connected to the BH bars (B1-B2), will manage the activation and regulation of the speed (rpm) of the connected fans. The activation and shutdown of the TRBH ventilation system, programmable on the thermometric devices, they will be anticipated by 10° C with respect to the FAN1 ON threshold (programmed on CH1-CH2-CH3): ON speed S1 and OFF speed S0, maximum speed S10 will reach at the threshold value of FAN1 ON.

FAN1 ON 70°C = S1 ON TRBH 61°C OFF TRBH 60°C (S1 = speed 1).

The speed regulation (rpm) on the fans is divided into 10 steps in relation to the temperature detected on the CHF channel and to the FAN 1 ON value, following the following combinations CH1 (M1-M6) - CH2 (M2-M5) - CH3 (M3-M4), selection of number of B2-M3 bars/fans.

**CHF 1.2.3:** e.g. FAN1 ON 70°C = **S1 ON TRBH 61°C, S2 62°C, S3 63°C, S4 64°C, S5 65°C, S6 66°C, S7 67°C, S8 68°C, S9 69°C, S10 70°C** (S10 = maximum speed).

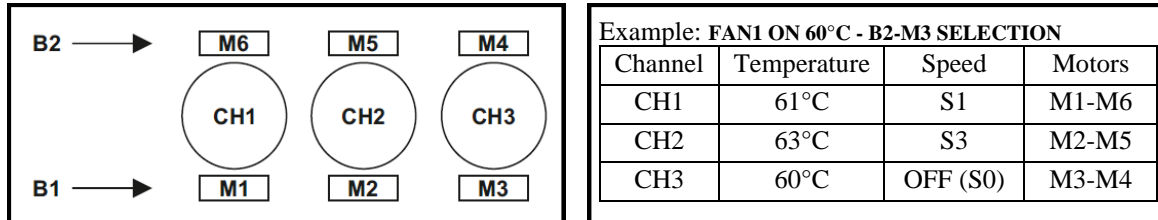

The speed regulation on the single CH 1-2-3 will allow to regulate the air flow inside the transformer columns, also introducing the following advantages:

- 1) Reduction of transformer thermal shock
- 2) Reduction in fan power consumption
- 3) Implementation of the fan fault signalling

The TRBH system programming includes the following selections:

**A)** TRBH system enabling, steps 6-7 page 13, YES/NO selection: **YES** (activates CH1-2-3) - **NO** (not active).

**B)** selection of number of bars and fans, steps 16-17 page 13, selection:

**B0-M0** = fans configuration disabled.

**B1-M1** = 1 bar (B1) 1 fan connected (M1), HOT reference channel (the hottest channel of CH1-CH2-CH3)

**B1-M2** = 1 bar (B1) 2 fans connected (M1-M2), ref. HOT channel (the hottest channel of CH1-CH2-CH3)

**B1-M3** = 1 bar (B1) 3 fans connected (M1-M2-M3), ref. Channel single CH1 (M1) CH2 (M2) CH3 (M3)

**B2-M1** = 2 bars (B1-B2) 2 fans connected (M1-M6), HOT reference channel (the hottest channel of CH1-CH2-CH3)

**B2-M2** = 2 bars (B1-B2) 4 connected fans (M1-M2-M5-M6), HOT reference channel (the hottest channel of CH1-CH2-CH3)

**B2-M3** = 2 bars (B1-B2) 6 fans connected (M1-M2-M3-M4-M5-M6) ref. Channel single CH1 (M1-M6) CH2 (M2-M5) CH3 (M3-M6)

**C)** setting the FAN threshold 1 ON (speed S1), steps 18-19 page 13, programmable according to the standard range 1°C at 230°C (range 0°C to 240°C) or 1°C 190°C (range -40°C to 200°C).

NOTE: fan speed regulation (rpm), with selections different from B1-3 and B2-3, is managed with reference HOT channel (the hottest channel of CH1-CH2-CH3). In the event of failure of one of the CH1-2-3 probes (FOC, FCC, FCD) the system automatically sets itself to speed S5 (M1-M2-M3-M4-M5-M6).

The speeds (rpm) of the S1-S2-S3- Sx fans. S10 and the TRBH system electrical connections are available on TRBH SYSTEM. manual.

The **FAN 2** via the supplementary probe (CH4/YES), dedicated to the room / core temperature, can be used to manage the possible ON / OFF activation of an extractor or alarm installed in the cabin. By combining the device with the TRBH extractor system, it will be possible to manage the ventilation of the cabin/box by adjusting the flow rate of the extractors to 10 speeds. the TRBH extractor system can be configured with a maximum of three extractors.

**FAN 2 YES/NO programming**, steps 14-15 page 13, YES (CH4 active) - NO (not active).

The programming of the TRBH extractor system provides for the following selections with the number of connected extractors, steps 20-21 page 14:

n 0 = no fan connected.

n 1 = 1 fan connected (M1), reference channel CH4

n 2 = 2 fans connected (M1-M2), reference channel CH4

n 3 = 3 fans connected (M1-M2-M3), reference channel CH4

**FAN 2 threshold ON**, steps 22-23 pages 13-14, (e.g. ON at 45°C – fixed switch-off (OFF) at 35°C).

Depending on the set threshold, the Fan OFF delta will always be 10°C with respect to the programmed threshold ON.

Threshold setting FAN 2 ON can be programmed according to the standard range 1°C to 230°C (range 0°C to 240°C) or 1°C 190°C (range -40°C to 200°C).

NOTE: fan speed adjustment (rpm), with selections other than M1-M2-M3, is managed with channel CH4. In case of failure of one of the CH4 probes (FOC, FCC, FCD) the system automatically sets itself to speed S5 (M1-M2-M3)

The speeds (rpm) of the fans S1-S2-S3-Sx.... S10 and the electrical connections of the TRBH system are available in the TRBH EXTRACTOR manual.

NOTE: when FAN2 is enabled on CH4, by disabling the extractor function TRBH (n\_0) it will be possible to manage the possible connection of an extractor or alarm installed in the cabin using the FAN2 relay. FAN 2 threshold ON, steps 22-23 pages 13-14, (eg. ON at 45°C – fixed switch-off (OFF) at 35°C). Depending on the set threshold, the Fan OFF delta will always be 10°C with respect to the programmed threshold ON.

### **TRBH FANS DIAGNOSTICS**

The NT935BH control unit, connected to the BH bars (B1-B2), is able to identify any faults on the ventilation bars. In the event of a fault, the display shows **BH Err** followed by the relevant indication:

**FLT RS1 or RSE:** communication failure with the B1 control box or extractor control box (RSE)

**FLT RS2:** communication failure with the B2 control box

**FLT B1 or EST:** failure of at least one motor on the B1 bar or of an extractor (EST)

**FLT B2:** failure of at least one motor on the bar B2

**FLT B1-B2:** failure of at least one motor on the B1 bar and B2 bar

The fault signal **BH Err** involves the switching of the FAULT contact of the control unit.

The NT935BH-D model, through the Modbus Mapping, also is used to monitor the speed (rpm) set by the control unit and the following failure cases for the single motor:

- motor over temperature (motor temperature over 70°C)
- general motor failure (motor blocked or under stress - impeller disconnected from the motor shaft - motor broken - errors or interruptions of electrical connections)

### **FAN TEST**

It is possible, by programming (**HF<sub>n</sub>**), to make sure that the fans are operated for 5 minutes every *xxx*" hours, regardless of the temperature values of the columns or the environment (e.g.: with HF<sub>n</sub> = 001 the fans are activated for 5 minutes every hour).

This function is designed to periodically check the operation of the fans and of their control equipment.

Setting **NO**, this function is inhibited.

To enable the HF<sub>n</sub> function, read the programming section on pages 13-14.



### **IMPORTANT INFORMATION**

**Before carrying out the isolation test of the electrical panel the control unit is installed on, disconnect it together with the sensors from the power supply to prevent it from being seriously damaged.**

## **OUTPUT ETHERNET MODBUS TCP**

### **INTRODUCTION TO THE ETHERNET MODULE**

The Ethernet connectivity of the new NT935BH ETH is used to implement the functions of the Tecsystem control units directly into your Modbus TCP maximum 8 node monitoring system.

The integrated module includes all the essential network features, among which a 10Base T/100Base-TX Ethernet connection, TCP/IP full stack suitable to work as Modbus TCP slave.

The unit can be used for remote configuration, monitoring in real time or problem solving.

The Windows-based Telnet system allows configuring the NT935BH ETH easily into a sub-network with specific IP addresses.

### **OPERATING NOTES**

The communication of the temperature control monitoring unit is active only when the NT935BH ETH is in temperature control mode (Scan, Auto, Man and T.Max).

When other functions such as programming, programming display and relay test are activated, the ModBus communication is temporarily deactivated.

### **DATA TRANSMISSION**

The Ethernet module allows you to connect to the control unit via Modbus TCP slave allowing you to: read the data indicated in the modbus table pag. 20 and to be able to write those indicated in the paragraph notes for remote programming.

The ETH module is always in slave mode.

The NT935BH ETH control unit is in communication with the network only when it is in temperature reading mode, while it is inactive when in the following modes: display, programming and test relays.

### **NOTES ON ETHERNET ELECTRICAL CONNECTIONS**

As to the signal cable to use in order to guarantee correct operation, it is necessary to use a CAT 7 Ethernet cable with RJ45 connector with the following specifications:

- 4 twisted pairs 23AWG
- Tinned copper braid with an 80% cover.
- Always position the Ethernet cable far away from power cables.

## FUNCTION CODE

The ModBus module supports the following function codes:

- 3<sub>(10)</sub>**: - holding register reading
- 16<sub>(10)</sub>**: - multiple registers writing

**If ModBus receives a message and a CRC error is detected, no answer is given.**

### CODE 3<sub>(10)</sub>.

Request:

Slave address, code 3<sub>(10)</sub>, Starting address HI, Starting address LO, Number of Point HI, Number of Point LO, Crc LO, Crc HI.

Response:

Slave address, code 3<sub>(10)</sub>, Byte count, Data HI, Data LO....., Crc LO, Crc HI.

### CODE 16<sub>(10)</sub>.

Request:

Slave address, code 16<sub>(10)</sub>, Starting address HI, Starting address LO, Number of Point HI, Number of Point LO, Byte count, Data HI, Data LO....., Crc LO, Crc HI.

Response:

Slave address, code 16<sub>(10)</sub>, Starting address HI, Starting address LO, Number of Register HI, Number of register LO, Crc LO, Crc HI.

## NOTES FOR REMOTE PROGRAMMING

The writeable registers are shown in TABLE MODBUS MAPPING referred to as W or RW (**write or read/write**). max number of registers 72, see table page 20.

Channels 1-3 cannot be disabled; in case of incorrect setting they are always forced as enabled channels.

In the case in which the channel 4 is not enabled and/or the information is not provided we have the following answers:

1. **Measured temperatures** = 0000 (0°C)
2. **Temperature AL./TRIP** = Value written in E2PROM
3. **Channel status** = 0000
4. **Channel setting** = %00000000; %xxxxxxx0 (x=n.d.)

In the event that information is sent in writing to a register can't be written (only READ) data will be trashed without affecting the received message.

Also in the remote programming phase via ModBus it must be considered that the Alarm thresholds must be lower than the Trip thresholds and that the Fan-on thresholds must be higher than the Fan-off thresholds.

In case you try to set these thresholds incorrectly, the control unit NT935BH ETH will not proceed with the programming and storage of data, therefore in subsequent readings will read the data from the previous schedule.

After having sent a request for writing the control unit will take a time of about 1 " to store the data in eeprom, during the step of storing the module ModBus will not be able to process additional requests.

If the demand for programming is successful, the unit automatically resets and loads the new settings.

The information "RELAY STATUS" indicates the state of excitation of the coils of the relays, so it will be subject to the commands of "FAIL SAFE".

At the end of the write command (Write) is carried out a check of compatibility data:

1. **If you have a non-compatibility "exception" for an answer and the data packet is rejected in its entirety. The code of the first erroneous data can be obtained by reading the log "Error received data". (NB: this code is lost during RESET or new power or writing data in E2PROM);**
2. **if the data are correct, they are transferred to the non-volatile memory (E2PROM), the historical data is reset (Tmax = 0°C) and a reset of the system is subsequently forced**
3. **If the WRITE command implies only writing "COMMANDS" it will be implemented autonomously and without RESET, i.e. without affecting the data of the control unit.**

### ERROR CODES (exception codes)

In case of a wrong request, ModBus will answer with modified codes and codified errors according to the following:

- 1: - Unsupported function code
- 2: - Wrong data address
- 3: - Wrong data (for instance length)

The memory area containing the HFN datum must undergo no forcing.

In the case in which all the fans are turned off (F1, F2) the test of the relay will not take place.

### UNACCEPTABLE DATA

There are some programmings that are not acceptable as they are not foreseen by the NT935BH ETH instrument; such data will be discarded without producing any error message (EXCEPTION CODE).

- CH 1-2-3: → channels that cannot be disabled
- CH 1-2-3: → FAN\_2 cannot be enabled
- CH 4: → FAN\_1 cannot be enabled
- CH 4: → FAN\_2 cannot be enabled if CH 4 = no

### ILLEGAL DATA

On the other hand, some combinations are programming errors because they are wrong settings; in this case the error code is ILLEGAL\_DATA, this information is accessible to ModBus reading the register 7.

|   |                |
|---|----------------|
| NO ERROR  | No error 00    |
| CH_1 Trip ≤ Alarm   | Code error 01  |
| CH_4 Trip ≤ Alarm   | Code error 04  |
| Value HFN > max see table: SYSTEM - Setting and Status    | Code error 020 |
| Value FCD > max see table: SYSTEM - Setting and Status    | Code error 021 |
| Value Voting > max see table: SYSTEM - Setting and Status | Code error 023 |

Note. If the value of Voting is higher than the max value expected for the model in question, it will be set equal to "0", that is NO\_VOTING.

### CONTROL UNIT GENERAL NOTES

The models of the unit can be equipped with different options; to avoid disruption of production their existence is defined by Fw indicated power, with messages dedicated on display LEDs.

This information can be accessed by reading the Modbus register 6 (option) with the following meaning:

#### LOW Byte

Bit\_1 = Ethernet

#### HIGH Byte

Bit\_0/1 = 00 - Range 0°C ÷ 240°C

Bit\_0/1 = 10 - Range -40°C ÷ 200°C

In the case of the Ethernet option the ModBus functions and 4.20 from the panel will be disabled while they will be readable from the centre. Note; in case the values programmed from ModBus are out of range, a date "exception" error response will be generated.

### MODBUS MAPPING TABLE

#### HEADER (Information and commands):

| Address<br>LO <sup>(10)</sup> | Data HI                     | Data LO                  | R: read<br>W: write<br>RW:<br>read/write |
|-------------------------------|-----------------------------|--------------------------|--|
| 1                             | Model – MSD (ASCII)         | Model - 3° Digit (ASCII) | R  |
| 2                             | Model - 2° Digit (ASCII)    | Model – LSD (ASCII)      | R  |
| 3                             | Space (20H)                 | Vers. Fw – MSD(ASCII)    | R  |
| 4                             | Vers. Fw - 2° Digit (ASCII) | Vers. Fw – LSD(ASCII)    | R  |
| 5                             | Qty channels (2*ASCII)      |                          | R  |
| 6                             | Options (see note)          | Options (see note)       | R  |
| 7                             | 00                          | Wrong datum received     | R-see tab.                               |
| 8                             | 00                          | Info various causes      | R-see tab                                |
| 9                             | 00                          | Controls                 | W-see tab.                               |

**SYSTEM: Setting and Status**

| Address LO (10) | Data HI | Data LO             | Notes 1                        | Notes 2   | R: read<br>W: write<br>RW: read/write |
|-----------------|---------|---------------------|--------------------------------|---|---------------------------------------|
| 10              | 00      | HFN (Fan test)      | 0=No test                      | 1÷200h  | RW                                    |
| 11              | 00      | FCD                 | temperature increment          | 0=No FCD<br>1÷30°/sec                                       | RW                                    |
| 12              | 00      | Voting              | 0=No Voting<br>1=YES           |   | RW                                    |
| 13              | 00      | CPU Setting         | See Notes                      |   | RW                                    |
| 14              | 00      | CPU Error           | See Notes                      |   | R                                     |
| 15              | 00      | Relays Status       | See Notes                      |   | R                                     |
| 16              | 00      | 420 mA channel      | reference channel for 4.20 mA  | 0 = hot<br>1÷4= ch1÷4<br>5 = scan                           | RW<br>Only for version AD             |
| 17              | 00      | Address             | Modbus address                 | 1÷255   | R                                     |
| 18              | 00      | Bdr                 | Modbus baud rate               | 0=2400<br>1=4800<br>2=9600<br>3=19200<br>4=38400            | R                                     |
| 19              | 00      | Parity              | Modbus parity bit              | 0=N-1 None (1Stop)<br>1=Even<br>2=Odd<br>3=N-2 None (2Stop) | R                                     |
| 20              | 00      | Bars/Fans Structure | See the TRBH notes on page 25. |   | R                                     |

**TEMPERATURE FANS:**

| Address LO (10) | Data HI       | Data LO       | Notes 1                        | Notes 2   | R: read<br>W: write<br>RW: read/write |
|-----------------|---------------|---------------|--------------------------------|-----------|---------------------------------------|
| 21              | 2'compl. sign | Fan_1 ON TRBH | 1°C ÷ 240°C<br>1°C ÷ 200°C (*) | MAX SPEED | RW                                    |
| 22              | 2'compl. sign | FREE          | See Notes                      |           | R                                     |
| 23              | 2'compl. sign | Fan_2 ON TRBH | 1° to÷ 240°<br>1°C ÷ 200°C (*) | MAX SPEED | RW                                    |
| 24              | 2'compl. sign | FREE          | See Notes                      |           | R                                     |

(\*) for version -40°C ÷ + 200°C

**TEMPERATURES channels 1÷4:**

(\*) for version - 40°C ÷ + 200°C

| Address LO<br>(10) | Data HI       | Data LO                                 | Notes 1                              | Notes 2  | R: read<br>W: write<br>RW: read/write |
|--------------------|---------------|---|--------------------------------------|----------|---------------------------------------|
| 25                 | 2'compl. sign | 2'compl. Ch1 temper.                    | -10°C ÷ 240°C<br>-48°C÷200°C<br>(*)  |          | R                                     |
| 26                 | 2'compl. sign | 2'compl. Ch1 max<br>temperat.           | 0°C ÷ 240°C<br>0°C÷200°C (*)         |          | R                                     |
| 27                 | 2'compl. sign | 2'compl. Ch1 temper.<br>alarm set point | 1°C ÷ 240°C<br>1°C÷200°C (*)         | (AL)     | RW                                    |
| 28                 | 2'compl. sign | 2'compl. Ch1 temper.<br>trip set point  | 1°C ÷ 240°C<br>1°C÷200°C (*)         | (TRP)    | RW                                    |
| 29                 | 2'compl. sign | 2'compl. Ch2 temper.                    | -10°C ÷ 240°C<br>-48°C÷200°C<br>(*)  |          | R                                     |
| 30                 | 2'compl. sign | 2'compl. Ch2 max<br>temperat.           | 0°C 240°C<br>0°C÷200°C (*)           |          | R                                     |
| 31                 | 2'compl. sign | 2'compl. Ch2 temper.<br>alarm set point | 1°C ÷ 240°C<br>1°C÷200°C (*)         | As (AL)  | R                                     |
| 32                 | 2'compl. sign | 2'compl. Ch2 temper.<br>trip set point  | 1°C ÷ 240°C<br>1°C÷200°C (*)         | As (TRP) | R                                     |
| 33                 | 2'compl. sign | 2'compl. Ch3 temper.                    | -10°C ÷ 240°C<br>-48°C÷200°C<br>(*)  |          | R                                     |
| 34                 | 2'compl. sign | 2'compl. Ch3 max<br>temperat.           | 0°C ÷ 240°C<br>0°C÷200°C (*)         |          | R                                     |
| 35                 | 2'compl. sign | 2'compl. Ch3 temper.<br>alarm set point | 1°C ÷ 240°C<br>1°C÷200°C (*)         | As (AL)  | R                                     |
| 36                 | 2'compl. sign | 2'compl. Ch3 temper.<br>trip set point  | 1°C ÷ 240°C<br>1°C÷200°C (*)         | As (TRP) | R                                     |
| 37                 | 2'compl. sign | 2'compl. Ch4 temper.                    | -10°C ÷ 240°C<br>-48°C÷200°C<br>(*)  |          | R                                     |
| 38                 | 2'compl. sign | 2'compl. Ch4 max<br>temperat.           | 0°C ÷ 240°C<br>0°C÷200°C (*)         |          | R                                     |
| 39                 | 2'compl. sign | 2'compl. Ch4 temper.<br>alarm set point | 1°C ÷ 240°C<br>1°C÷200°C (*)         | (AL)     | RW                                    |
| 40                 | 2'compl. sign | 2'compl. Ch4 temper.<br>trip set point  | 1°C ÷ 240°C<br>1°C÷200°C (*)         | (TRP)    | RW                                    |
| 41                 | 00            | 00                                      |                                      |          | R                                     |
| 42                 | 00            | 00                                      |                                      |          | R                                     |
| 43                 | 00            | 00                                      |                                      |          | R                                     |
| 44                 | 00            | 00                                      |                                      |          | R                                     |
| 45                 | 00            | TRBH_1 speed                            | M1-M6 motors                         |          | R                                     |
| 46                 | 00            | TRBH_1 motors status<br>Bars 1/2        | See the TRBH<br>notes on page<br>25. |          | R                                     |
| 47                 | 00            | 00                                      |                                      |          | R                                     |

|    |    |                                  |                                      |  |   |
|----|----|----------------------------------|--------------------------------------|--|---|
| 48 | 00 | 00                               |                                      |  | R |
| 49 | 00 | TRBH_2 speed                     | M2-M5 motors                         |  | R |
| 50 | 00 | TRBH_2 motors status<br>Bars 1/2 | See the TRBH<br>notes on page<br>25. |  | R |
| 51 | 00 | 00                               |                                      |  | R |
| 52 | 00 | 00                               |                                      |  | R |
| 53 | 00 | TRBH_3 speed                     | M3-M4 motors                         |  | R |
| 54 | 00 | TRBH_3 motors status<br>Bars 1/2 | See the TRBH<br>notes on page<br>25. |  | R |
| 55 | 00 | 00                               |                                      |  | R |
| 56 | 00 | 00                               |                                      |  | R |

(\*) for version  $-40^{\circ}\text{C} \div +200^{\circ}\text{C}$

**CHANNELS 1÷4: Setting**

| Address LO<br>(10) | Data HI | Data LO     | Notes 1       | Notes 2 | R: read<br>W: write<br>RW: read/write |
|--------------------|---------|-------------|---------------|---------|---------------------------------------|
| 57                 | 00      | Ch1 Setting | See Notes CHx |         | RW                                    |
| 58                 | 00      | Ch2 Setting | See Notes CHx |         | R                                     |
| 59                 | 00      | Ch3 Setting | See Notes CHx |         | R                                     |
| 60                 | 00      | Ch4 Setting | See Notes CHx |         | RW                                    |
| 61                 | 00      | 00          | --            |         | R                                     |
| 62                 | 00      | 00          | --            |         | R                                     |
| 63                 | 00      | 00          | --            |         | R                                     |
| 64                 | 00      | 00          | --            |         | R                                     |

**CHANNELS 1÷4: Status**

| Address LO<br>(10) | Data HI   | Data LO    | Notes 1       | Notes 2 | R: read<br>W: write<br>RW: read/write |
|--------------------|-----------|------------|---------------|---------|---------------------------------------|
| 65                 | Ch1 story | Ch1 status | See Notes CHx |         | R                                     |
| 66                 | Ch2 story | Ch2 status | See Notes CHx |         | R                                     |
| 67                 | Ch3 story | Ch3 status | See Notes CHx |         | R                                     |
| 68                 | Ch4 story | Ch4 status | See Notes CHx |         | R                                     |
| 69                 | 00        | 00         | --            |         | R                                     |
| 70                 | 00        | 00         | --            |         | R                                     |
| 71                 | 00        | 00         | --            |         | R                                     |
| 72                 | 00        | 00         | --            |         | R                                     |

**Various registers extractors**

| Address LO <sup>(10)</sup> | Data HI | Data LO                   | Note 1                | Note 2     | R: read<br>W:write<br>RW: read/write |
|----------------------------|---------|---------------------------|-----------------------|------------|--------------------------------------|
| 73                         | 00      | Umber of Extractor TRBH   | Valori=00-03          |            | R                                    |
| 74                         | 00      | Extractor's speed RBH_M1  |                       |            | R                                    |
| 75                         | 00      | Motor status TRBH_M1      | See Note TRBH page 25 |            | R                                    |
| 76                         | 00      | Extractor's speed TRBH_M2 |                       | as TRBH_M1 | R                                    |
| 77                         | 00      | Motor status TRBH_M2      | See Note TRBH page 25 |            | R                                    |
| 78                         | 00      | Extractor's speed TRBH_M3 |                       | as TRBH_M1 | R                                    |
| 79                         | 00      | Motor status TRBH_M3      | See Note TRBH page 25 |            | R                                    |
| 80                         | 00      | 00                        |                       |            | R                                    |

**REGISTERS NOTES**

**INFO various causes (READ)**

| BIT 7 | BIT 6 | BIT 5 | BIT 4 | BIT 3 | BIT 2 | BIT 1 | BIT 0                         |
|-------|-------|-------|-------|-------|-------|-------|-------------------------------|
| --    | --    | --    | --    | --    | --    | --    | (*) RESET (R) has taken place |

**COMMANDS (WRITE)**

| BIT 7 | BIT 6 | BIT 5 | BIT 4 | BIT 3 | BIT 2                    | BIT 1                     | BIT 0                                |
|-------|-------|-------|-------|-------|--------------------------|---------------------------|--------------------------------------|
| --    | --    | --    | --    | --    | (*) Reset Reg. CPU_Error | (*) Reset historical data | (*) Reset BIT: RESET has taken place |

**CHn SETTING**

| BIT 7 | BIT 6 | BIT 5 | BIT 4 | BIT 3 | BIT 2          | BIT 1     | BIT 0       |
|-------|-------|-------|-------|-------|----------------|-----------|-------------|
| --    | --    | --    | --    | --    | FAN2 TRBH EXT. | FAN1 TRBH | CAN_enabled |

**CHn STATUS**

| BIT 7 | BIT 6 | BIT 5 | BIT 4           | BIT 3     | BIT 2 | BIT 1 | BIT 0 |
|-------|-------|-------|-----------------|-----------|-------|-------|-------|
| --    | TRIP  | ALARM | FAN_2 TRBH EXT. | FAN1 TRBH | FCD   | FOC   | FCC   |

**CHn STORY**

| BIT 7 | BIT 6 | BIT 5 | BIT 4 | BIT 3 | BIT 2 | BIT 1 | BIT 0 |
|-------|-------|-------|-------|-------|-------|-------|-------|
| --    | TRIP  | ALARM | --    | --    | --    | FOC   | FCC   |

**RELAY STATUS (coil energizing status)**

| BIT 7 | BIT 6 | BIT 5 | BIT 4            | BIT 3           | BIT 2            | BIT 1            | BIT 0            |
|-------|-------|-------|------------------|-----------------|------------------|------------------|------------------|
| --    | --    | --    | Relay FAULT 1=ON | TRIP Relay 1=ON | ALARM Relay 1=ON | FAN_2 Relay 1=ON | FAN_1 Relay 1=ON |

**CPU ERROR**

| BIT 7 | BIT 6 | BIT 5          | BIT 4      | BIT 3    | BIT 2 | BIT 1     | BIT 0 |
|-------|-------|----------------|------------|----------|-------|-----------|-------|
| --    | --    | FAULT TRBH EST | FAULT TRBH | PT ERROR | CAL   | FCD Fault | ECH   |

### CPU SETTING

| BIT 7 | BIT 6 |  |  | BIT 5 | BIT 4          | BIT 3         | BIT 2          | BIT 1 | BIT 0 |
|-------|-------|--|--|-------|----------------|---------------|----------------|-------|-------|
| --    | --    |  |  | --    | Failsafe fault | Failsafe trip | Failsafe alarm | --    | --    |

### BARS/FANS STRUCTURE

| BIT 7 | BIT 6 | BIT 5         | BIT 4 | BIT 3 | BIT 2 | BIT 1                       | BIT 0 |
|-------|-------|---------------|-------|-------|-------|-----------------------------|-------|
| --    | --    | Num. Bars 1;2 |       | --    | --    | Num. Motors for bar 1; 2; 3 |       |

Bar programming TRBH Bit 5-4:0 0 = NO BARS  
0 1=BAR1  
1 0=BAR1-2

Programming of motors TRBH Bit 0-1: 0 0 = NO motors  
0 1 = M1  
1 0 = M1-M2  
1 1 = M1-M2-M3

### TRBH BAR'S MOTORS STATUS

| BIT 7 | BIT 6 | BIT 5 | BIT 4 | BIT 3              | BIT 2 | BIT 1              | BIT 0 |
|-------|-------|-------|-------|--------------------|-------|--------------------|-------|
| --    | --    | --    | --    | Motor status Bar_2 |       | Motor status Bar_1 |       |

TRBH motor status: 00=OK  
10=overtemperature

01=general motor fault  
11= communication failure with the control box/bar

### EXTRACTOR BH NUMBER

| BIT 7 | BIT 6 | BIT 5 | BIT 4 | BIT 3 | BIT 2 | BIT 1                       | BIT 0 |
|-------|-------|-------|-------|-------|-------|-----------------------------|-------|
| --    | --    | --    | --    | --    | --    | Num. Motors for est 1; 2; 3 |       |

Programming of motors TRBH Bit 0-1: 0 0 = NO motors  
0 1 = M1  
1 0 = M1-M2  
1 1 = M1-M2-M3

### TRBH EXTRACTOR MOTORS STATUS

| BIT 7 | BIT 6 | BIT 5 | BIT 4 | BIT 3 | BIT 2 | BIT 1            | BIT 0 |
|-------|-------|-------|-------|-------|-------|------------------|-------|
| --    | --    | --    | --    | --    | --    | Motor status est |       |

TRBH motor status: 00=OK  
10=overtemperature

01=general motor fault  
11= communication failure with the control box/bar

## FUNZIONE FAIL SAFE

The NT935 ETH control unit has the selection n.o (normally open contact)/n.c (normally closed contact) for the ALARM, TRIP and FAULT relays, programming steps from 30 to 35 page 14. Selecting the YES/NO setting introduces the Fail Safe and No fail safe functions.

#### ALARM AND TRIP

By setting NO (NO Fail safe) the normally open contacts are in positions 5-7 Alarm and 8-10 Trip, they switch only when the pre-set temperature limits are reached.

By setting YES (Fail safe), the normally closed contacts are in positions 5-7 Alarm and 8-10 Trip, they switch only when the pre-set temperature limits are reached or as a result of no voltage on the device.

#### FAULT

By setting YES (Fail safe), contact 11-12 is positioned as normally open, switches (closed) when a fault condition is identified; see paragraph on alarms and ventilation on page 12.

Setting NO (NO Fail safe) the contact 11-12 is positioned as normally closed, switches (open) when a fault condition is identified; see paragraph on alarms and ventilation on page 12.

If the fail safe function is disabled on the fault contact, the control unit will no longer be able to signal the fault due to power failure. In this case it is advisable to enable the Fail safe on the ALARM contact for the afore-mentioned indication.

NOTE: NOTE: when the control unit is in one of the modes indicated below, it does not perform any thermal monitoring, moreover the relays will all be disabled the FAULT led will flash.

- Vis. display programming.
- PRG programming.
- Test of the relays.

The FAIL SAFE function is temporarily disabled and the FAULT relay switches.

**ATTENTION: accessing at the relay test mode will temporarily disable the failsafe function, the relays with function enabled switch (ALARM-TRIP-FAULT).**

## ETHERNET MODULE PROGRAMMING PARAMETER

X Windows Vista, 7, 8.

### ETH0 CONNECTIONS

Using an Ethernet cable, connect the ETH0 RJ45 of the NT935BH ETH control unit to the Ethernet card of a PC.

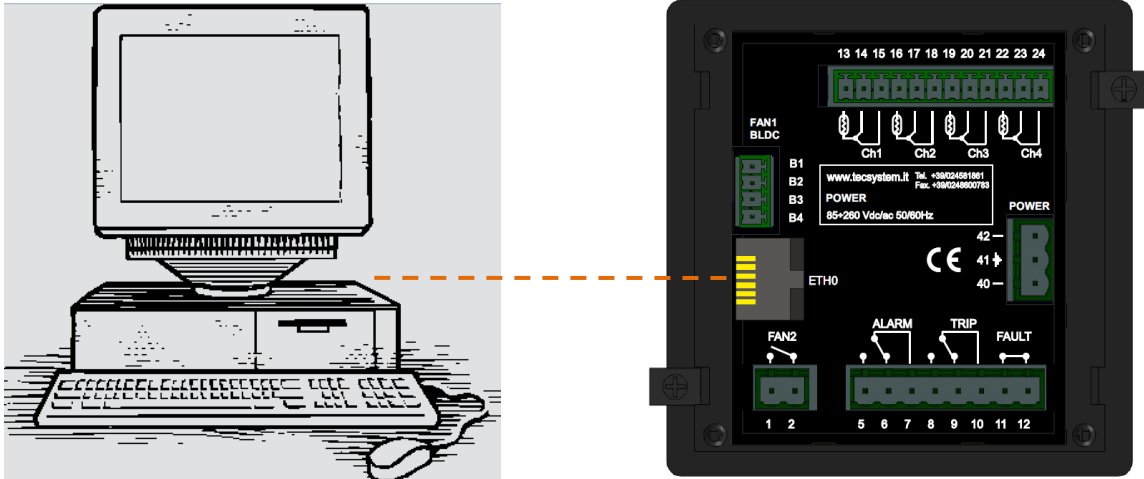

### TELNET ENABLING

Use the Telnet program to set the Ethernet IP parameters.

1) START menu (Windows)

If already enabled, the program appears

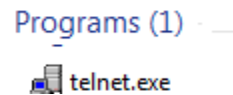
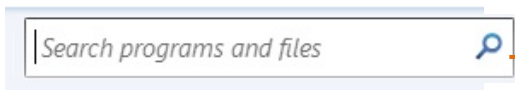

2) Start the search with the Telnet program  
Entering telnet in SEARCH.

Press ENTER to launch the program.

(Skip step 12 page 27)

If the Telnet program is not enabled:

3) START menu (Windows):

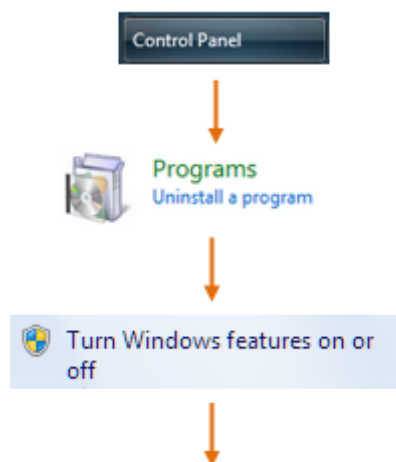

4) Select Control panel

5) Select Programs, followed by Features or Programs and Features

6) Select Turn Windows features on or off

7) Enable Telnet Client and click "OK"

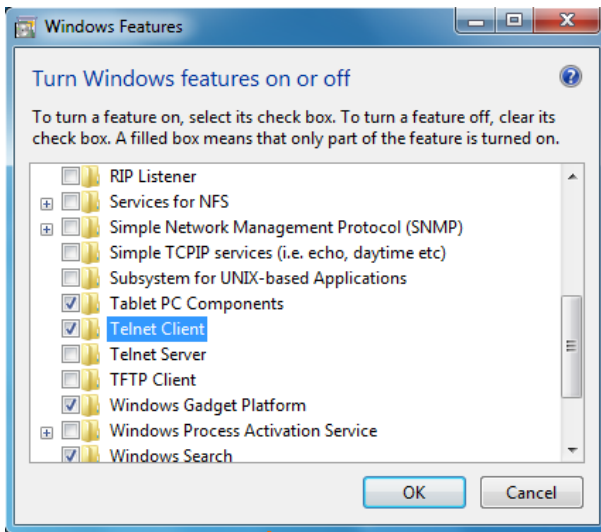

The screen below will open.  
Wait for the Telnet function to activate.

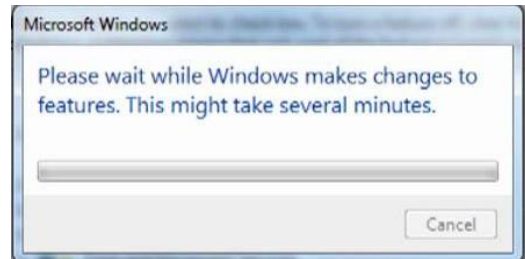

Programs (1) —

telnet.exe

8) Close the open screens and restart the PC if required

9) START menu (Windows)

10) Search for the Telnet program

11) Press ENTER to launch the program

12) TELNET SCREEN

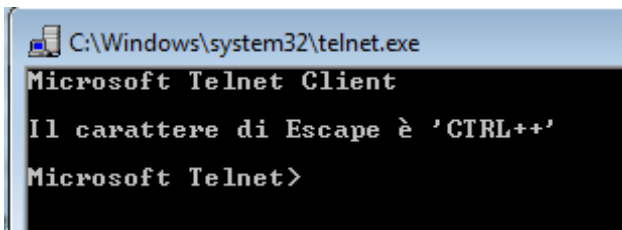

13) Type in: OPEN

14) Press ENTER

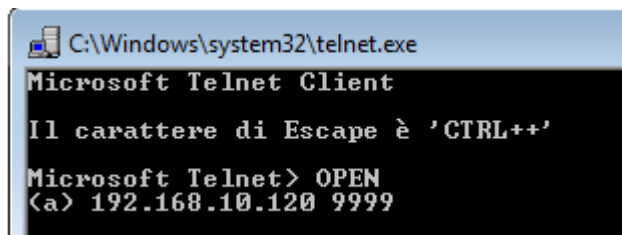

15) Type in: 192.168.10.120 9999

16) Press ENTER

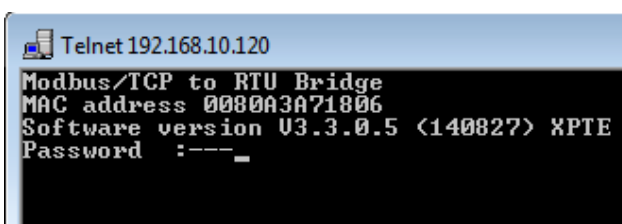

17) Enter the Password: TECS

18) Press ENTER

Note: In this screen we have the **MAC address** and the **software** version of the ETH port available.

## 19) IP PARAMETER PROGRAMMING MENU

```
Telnet 192.168.10.120
Modbus/TCP to RTU Bridge
MAC address 0080A3A71806
Software version U3.3.0.5 <140827> XPTC
Password :----
Press Enter for Setup Mode

Model: Device Server Plus+! <Firmware Code:YM>

Modbus/TCP to RTU Bridge Setup
1) Network/IP Settings:
   IP Address ..... 192.168.10.120
   Default Gateway ..... 192.168.10.1
   Netmask ..... 255.255.255.0
   Telnet config password set
2) Serial & Mode Settings:
   Protocol ..... Modbus/RTU,Slave(s) attached
   Serial Interface ..... 19200,8,E,1,RS485
3) Modem/Configurable Pin Settings:
   CP1 ..... RS485 Output Enable
   CP2 ..... Not Used
   CP3 ..... Not Used
4) Advanced Modbus Protocol settings:
   Slave Addr/Unit Id Source .. Modbus/TCP header
   Modbus Serial Broadcasts ... Disabled <Id=0 auto-mapped to 1>
   MB/TCP Exception Codes ..... Yes <return 00AH and 00BH>
   Char. Message Timeout ..... 00050msec, 05000msec
7) Security Settings:
   SNMP ..... Enabled
   SNMP Community Name ..... public
   Telnet Setup ..... Enabled
   TFTP Download ..... Enabled
   Port 77FEh ..... Enabled
   Web Server ..... Enabled
   Enhanced Password ..... Disabled
   Port 77F0h ..... Enabled

D)default settings, S)ave, Q)uit without save
Select Command or parameter set <1..7> to change: _
```

### IP PARAMETER PROGRAMMING MENU (TELNET)

The TELNET menu allows you to modify the configuration parameters of the Ethernet port.

The information available to you is:

#### Operator modifiable parameters.

- 1) Parameter modification (IP Address - Gateway- Netmask -Telnet password).

#### Parameters that cannot be modified by the operator

- 2) Communication parameters between the ETH0 port and the control unit.
- 3) Communication configuration between the ETH0 port and the control unit.
- 4) Communication advanced settings between the ETH0 port and the control unit.
- 7) Security settings between the ETH0 port and the control unit.



#### IMPORTANT INFORMATION

For a correct operation of the device it is advised not to access or modify menus 2-3-4-7. Changing the values contained in the indicated menus could lead to communication anomalies with loss of IP Ethernet communication.

**MENU MODIFICATION PROCEDURE 1) IP parameters:**

enter the command: 1

```
IP Address: IP Address <192> 192.<168> 168.<010> .<120> 120_
```

1) Enter the desired new IP address, if you wish to keep the set address press ENTER 4 times.

- At the end of the operation, the system will ask if you wish to modify the Gateway IP:

```
IP Address <192> 192.<168> 168.<010> .<120> 120  
Set Gateway IP Address <N> ?
```

Type in: **Y** to modify the Gateway IP.

**N** not to modify the Gateway IP and go to the following step.

2) Enter the desired new Gateway IP address, press ENTER; if you wish to keep the set address press ENTER 4 times.

```
IP Address <192> 192.<168> 168.<010> .<120> 120  
Set Gateway IP Address <N> ? Y  
Gateway IP Address : <192> 192.<168> 168.<010> 10.<001> 001_
```

- At the end of the operation, the system will ask if you wish to modify Netmask:

```
IP Address <192> 192.<168> 168.<010> .<120> 120  
Set Gateway IP Address <N> ? Y  
Gateway IP Address : <192> 192.<168> 168.<010> 10.<001> 001  
Set Netmask <N for default> <N> ?
```

Type in: **Y** to modify Netmask.

**N** not to modify Netmask and go to the following step.

3) Enter the new Netmask, press ENTER; if you wish to keep the set address press ENTER 4 times.

```
IP Address <192> 192.<168> 168.<010> .<120> 120  
Set Gateway IP Address <N> ? Y  
Gateway IP Address : <192> 192.<168> 168.<010> 10.<001> 001  
Set Netmask <N for default> <N> ? Y  
<255> .<255> .<255> .<000> _
```

- At the end of the operation, the system will ask if you wish to modify the Telnet Password:

```
IP Address <192> 192.<168> 168.<010> .<120> 120  
Set Gateway IP Address <N> ? Y  
Gateway IP Address : <192> 192.<168> 168.<010> 10.<001> 001  
Set Netmask <N for default> <N> ? Y  
<255> .<255> .<255> .<000>  
Change telnet config password <N> ? _
```

Type in: **Y** to modify the Telnet Password.

**N** not to modify the Telnet Password and go to the following step.

```

IP Address (192) 192.(168) 168.(010) .(120) 120
Set Gateway IP Address (N) ? Y
Gateway IP Address : (192) 192.(168) 168.(010) 10.(001) 001
Set Netmask (N for default) (N) ? Y
(255) .(255) .(255) .(000)
Change telnet config password (N) ? Y
Enter new Password:

```

4) Enter the new Telnet Password (4 digits max), press ENTER; if you wish to keep the set Password, press ENTER.

```

D)default settings, S)ave, Q)uit without save
Select Command or parameter set (1..7) to change: _

```

Type in: S to save the modified data.

Q to exit Telnet without saving the data.

The following screen appears:

```

D)default settings, S)ave, Q)uit without save
Select Command or parameter set (1..7) to change:
→ Parameters saved, Restarting ...

Connessione all'host perduta.
Premere un tasto per continuare..._

```

To check the programmed parameters or repeat programming, follow the TELNET SCREEN from step 12 to step 19, page 27.

Indications of LEDs 1-2 of the Ethernet port:

LED 1: Link

- > Off = No link
- > Amber = 10 Mbps
- > Green = 100 Mbps

LED 2: Activity

- > Off = No Activity
- > Amber = Half Duplex
- > Green = Full Duplex



## TECHNICAL SPECIFICATIONS OF THE EXTENSION CABLE FOR Pt100

1. Cable 20 x AWG 20/19 Cu/Sn
2. Section 0.55 mm<sup>2</sup>
3. Flame-protection insulation PVC105
4. Standards CEI 20.35 IEC 332.1
5. Maximum operating temperature: 90°C
6. Configuration: 4 triples of three twisted and coloured conductors
7. Screen on Cu/Sn
8. Fireproof PVC sheath
9. Outer diameter 12 mm
10. Standard configuration in 100 m coils

## FCD FUNCTION

The NT series equipment boasts an innovative control function combined with the dynamic status of the Pt100 sensor.

Activating FCD, the control unit analyses the increase in temperature  $\Delta T$  (\*) recorded in a second (**°C/sec**).

Enabling the function, the user can select the value ( $\Delta T$ ) from a minimum of 1°C/sec up to a maximum of 30°C/sec. If the measured value is higher than the value set by the user, the control unit inhibits any activation of the ALARM and TRIP alarms and activates the switching of the FAULT relay (11-12), signalling on the display "**fault for Fcd**".

e.g. setting the function to 5°C, the fault switching for FCD will only be activated if the control unit detects an increase  $\Delta T$  higher than 5°C in one second on the monitored system.

Setting "no" the FCD function is disabled.

When a channel is in Fault for FCD, the relative alarm and trip signals are inhibited on the single channel; therefore only the anomaly of excessively rapid increase of the temperature is signalled.

Press Reset to cancel the FCD signals of all the channels and reset the relay fault.

### Possible applications of FCD

#### Identification of a possible induced interference on the Pt100 sensor line

If the installation instructions are not complied with (see page 15), any interference on the Pt100 sensor line can cause false readings or anomalous alarms.

Setting the FCD function in a temperature range of between 1°C and 10°C (5°C recommended), the effects caused by false readings can be suppressed and the alarm relay activation can be prevented, as shown above.

Corrective actions: check the installation of the sensor extension cable is in line with the instructions given in the paragraph on the measurement signal transfer on page 15.

#### Identification of a sensor fault or faulty connection

In case of a faulty connection or sensor fault, a quick positive or negative variation in temperature might occur, leading to the system tripping or the alarms of the monitored system to be triggered.

In this specific case we recommend the FCD function to be set in a temperature range of between 10°C and 20°C.

Corrective actions: check the terminals the sensor is connected to are tightened and replace the faulty sensor, if required.

#### Identification of the electrical motor rotor block

In case of temperature control of the electrical motors, the quick temperature increase might be due to a blocked rotor.

In this specific case, it is advisable to set the FCD function in a temperature range of between 20°C and 30°C. This setting is recommended in order to avoid activation of the FCD function during the motor starting phase, i.e. where the increase has a very rapid variation.

(\*) The  $\Delta T$  value shows the temperature range for each second.

**NOTE: it is advisable not to enable the FCD function with VOTING active.**

## WARRANTY REGULATIONS

The purchased Product is covered by the manufacturer's or seller's warranty under the terms and conditions indicated in the "Tecsystem s.r.l. General Sales Conditions", which can be consulted on the website [www.tecsystem.it](http://www.tecsystem.it) and/or in the stipulated purchase contract.

The warranty is considered valid only when the product is damaged by causes attributable to TECSYSTEM srl, such as manufacturing or components defects.

The warranty is invalid if the Product proves to have been tampered with/modified or incorrectly connected and causing voltages outside the set limits and does not comply with the technical data for use and assembly, as described in this instruction manual.

The warranty is always ex Corsico as stated in the "General Conditions of Sale".

| TROUBLESHOOTING  | CAUSES AND SOLUTIONS   |
|--|--|
| The control unit does not switch on and the supply to terminals 40-42 is correct.                            | Check that: the connector is firmly inserted in its place, the connection wires are tight and that there are no obvious signs of burns on the connectors. Turn off the power supply and carry out the above instructions, restore the voltage. |
| CH4 is in FAULT for FOC<br>(only the 3 Pt100 sensors are connected)  | Programming error of the CH4/YES control unit. <i>Check and repeat the programming on page 13-14 select CH4 /NO.</i>   |
| One of the three/four channels is in FAULT for FOC/FCC   | Check the connections of the Pt100 probes, check the indications given in the paragraphs: <i>transfer of the measurement signals and diagnostics of the temperature probes page 14-15.</i>   |
| When turned on, the indication "ECH" appears   | A strong disturbance has damaged the memory data. See the paragraph for programmed data diagnostics on page 16.  |
| All the Pt100 sensors are in FCC.  | Incorrect sensor connection, the terminal block has been inserted upside down. <i>Check the connections and the terminal board.</i>  |
| The temperature shown by one or more channels is wrong.  | Contact the <i>TECSYSTEM</i> Technical Department.   |
| Sudden trip of the main switch. The temperature is on standard levels. Just one channel has caused the trip. | Check the temperatures recorded in T-MAX, check the indications given in the paragraphs: <i>transfer of measurement signals and temperature probe diagnostics pag.16. Activate the FCD function.</i>   |
| FCD warning  | See the FCD function on page 31.   |
| The control unit signals BH ERR RS1 or RSE   | Check the connection between the control unit and the Control box BAR B1 or to the extractor control box RSE, TRBH SYSTEM manual.  |
| The control unit signals BH ERR RS2  | Check the connection between the BAR B1 Control box and the B2 Control box, TRBH SYSTEM manual.  |
| The control unit signals BH ERR B1 or EST  | Check the operating status and the connection of the motors installed on the B1 bar or connected to the EST extractor control box, TRBH SYSTEM manual.   |
| The control unit signals BH ERR B2   | Check the operating status and connection of the motors installed on the B2 bar, TRBH SYSTEM manual  |
| The control unit signals BH ERR RS1  | Check the connection between the control unit and the BAR B1 Control box, TRBH SYSTEM manual.  |
| Contact the <i>TECSYSTEM</i> Technical Department if the problem persists.                                   |  |

## EQUIPMENT DISPOSAL

The European Directive 2012/19/EU (WEEE) has been approved to reduce waste electrical and electronic equipment and to encourage the recycling and re-use of materials and components of these appliances, thus reducing the disposal of harmful residues and compounds deriving from electrical and electronic equipment



All the electrical and electronic equipment supplied after 13 August 2005 is marked with this symbol, pursuant to European directive 2012/19/EU on electrical and electronic waste (WEEE). Any electrical or electronic equipment marked with this symbol must be disposed of separately from normal domestic waste.

Returning of used electrical appliances: contact TECSYSTEM or the TECSYSTEM agent to receive information on correct disposal of the appliances.

TECSYSTEM is aware of the impact its products have on the environment and asks its customers active support in the correct and environmentally-friendly disposal of its devices.

## USEFUL CONTACTS

TECHNICAL INFORMATION: [ufficiotecnico@tecsystem.it](mailto:ufficiotecnico@tecsystem.it)

COMMERCIAL INFORMATION: [info@tecsystem.it](mailto:info@tecsystem.it)

