

# INSTRUCTION MANUAL

## TTG SERIES FANS

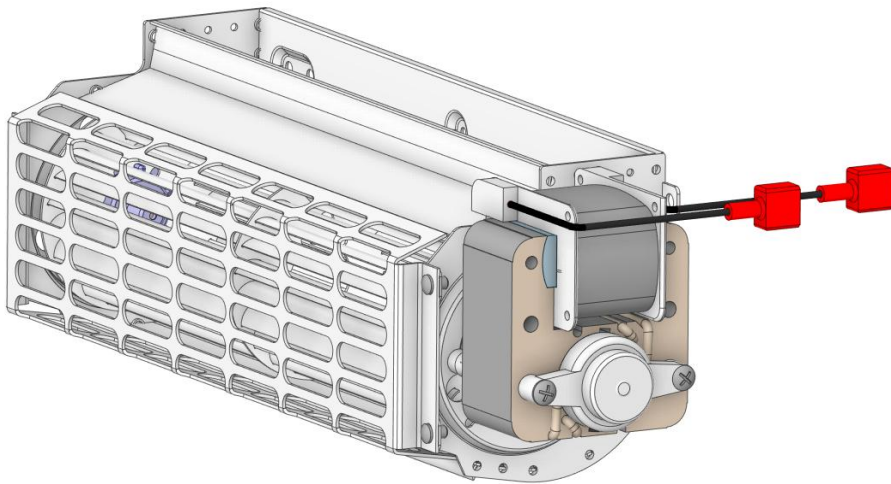

1MN0069 Rev. 4



operates with ISO9001 certified quality system

**TECSYSTEM S.r.l.**  
20094 Corsico (MI)  
Tel.: +39-024581861

<http://www.tecsystem.it>

R. 1.7 10/07/25

ENGLISH

“Translations of the original instructions”

## INTRODUCCION

First of all thank you for choosing and using TECSYSTEM product, we strongly suggest you to read carefully this instruction manual. It will allow you to understand how to use the system and take full advantage of all its features.

**WARNING! THIS MANUAL IS VALID AND COMPLETE ONLY FOR THE FANS MODEL: TTG240, TTG300 AND TTG360.**

## INDEX

	PAGE
1) SAFETY REGULATIONS .....	3
2) TECHNICAL SPECIFICATIONS .....	4
3) MAIN PARTS .....	—
4) MOUNTING .....	5
• SIZE FAN TTG240 .....	—
• SIZE FAN TTG300 .....	6
• SIZE FAN TTG360 .....	7
5) MOUNTING NOTES .....	8
• POWER SUPPLY .....	—
• ENVIRONMENTAL CONDITIONS OF USE .....	—
• MAINTENANCE .....	—
6) DIAGNOSTIC FAULT .....	9
7) WARRANTY CONDITIONS .....	—
8) EQUIPMENT DISPOSAL .....	—
9) USEFUL CONTACTS .....	—

## SAFETY REGULATION



### WARNING:

Carefully read the manual before using the fan. Keep these instructions for future reference.



Do not touch/disassemble the fans while they are running: **RISK OF INJURY**. The product should be installed in a location with restricted access to qualified personnel. Any work on the appliance must be referred to a qualified repair technician.



Do not touch the motor or power cords. Contact with a voltage of 230/120 Volts AC can be fatal. To reduce the risk of electric shock, do not disassemble or modify the blower motor under any circumstances. **Before connecting the system to the power supply, make sure that all connections have been made correctly.** Always disconnect the fan from the power supply before performing any type of maintenance.



Never touch the fan motor burns danger: **RISK INJURY**.

**Failure to follow these instructions can cause damage, fire or electric shock, with possible serious injury!**

### POWER SUPPLY

Before using it make sure that the power supply wires are not damaged, kinked or crushed. Do not tamper with the power supply wires. Never disconnect the power supply by pulling the cable, avoid touching the pins. Do not perform connection/disconnection operations with wet hands. Do not use objects as levers to disconnect the power supply of the system. Disconnect the power immediately if it is evident that the system gives off a burning smell or smoke, please contact technical support Tecsystem.

### LIQUIDS

Do not expose the product to dripping or splashing liquids. Do not allocate in places where humidity is over 90% and never touch with wet hands.

### CLEANING

Before cleaning the fan always disconnect the power supply. To avoid malfunctions, cleaning the fan only using compressed air to remove dust and dirt. Do not use oils or fats of any kind.

### OBJECTS

Never push objects through the air inlet or outlet, if this happens, disconnect the fan and call a technician.

### RESTRICTED USE A COMPETENT PERSON

The product is a sophisticated electromechanical system, absolutely not suitable for use by untrained personnel. All work must be performed by a qualified technician.

### ACCESSORIES

Do not use accessories or replacement parts that are not original, it could cause damage to the fan and put at risk the safety of the user. In case of failure, contact technical support.

### LOCATION

Install the fan indoor protected from splashing water and sunlight. Do not place near heat sources exceed the parameters specified in this manual. Place the fan in a horizontal and stable surface, away from vibration. The product must be installed in a location with limited access to qualified technician.

### RIPAIR

Do not repair or adjust the fan. If any fault occurs, do not hesitate to contact, always contact a qualified technician. Opening the fan tampering involves the automatic invalidation of the warranty.

### PRODUCTION

The date and the batch production of the device are shown on the label attached on the fan. Removing the label implies the automatic invalidation of the warranty.

### TECHNICAL SUPPORT

**Mail: [ufficiotecnico@tecsystem.it](mailto:ufficiotecnico@tecsystem.it) — tel: 02/4581861**

TECHNICAL SPECIFICATIONS	TTG240	TTG300	TTG360	TTG240	TTG300	TTG360
POWER SUPPLY	230 Vac ± 10% 50Hz			230 Vac ± 10% 60Hz		
MOTOR MOUNTING	0°	0°	0°	0°	0°	0°
CORRENT	210mA	220mA	230mA	314mA	415mA	469mA
POWER	31 W	32 W	34.5 W	40W	52W	57W
FLOW	200 m3/h	240 m3/h	260 m3/h	230 m3/h	250 m3/h	331 m3/h
NOISE LEVEL	50 dB(A)	50 dB(A)	50dB(A)	<60 dB(A)	<60 dB(A)	<60dB(A)
STATIC PRESSURE	53 Pa	54 Pa	50 Pa	53 Pa	73 Pa	53 Pa
DIAMETER IMPELLER	60 mm	60 mm	60 mm	60 mm	60 mm	60 mm
LENGTH IMPELLER	240 mm	300 mm	360 mm	240 mm	300 mm	360 mm
INSULATION CLASS	F	F	F	F	F	F
IP PROTECTION	IPX0	IPX0	IPX0	IPX0	IPX0	IPX0

NOTE: the technical data of the product may be subject to variations depending on the installation

### MAIN PARTS

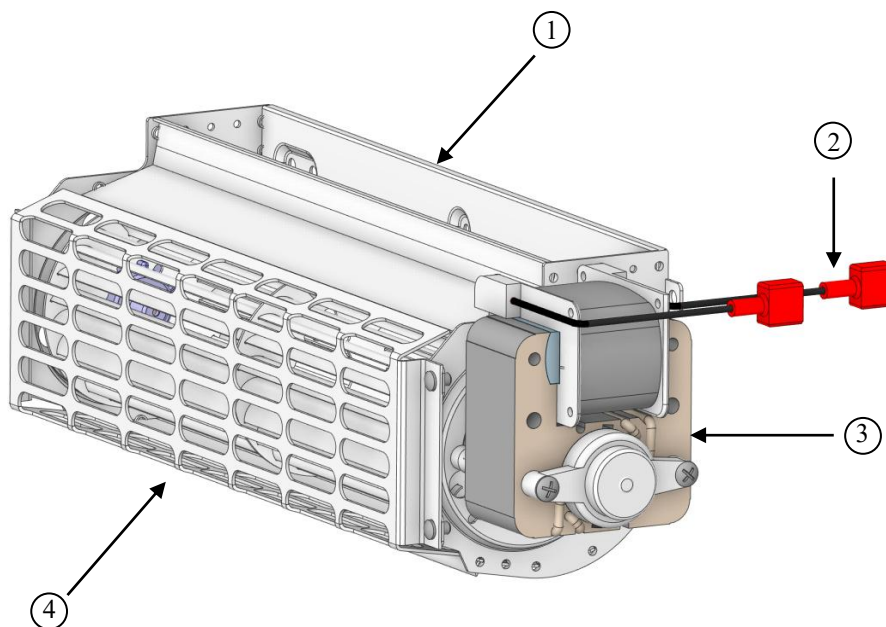

1MN0070 REV.4

1)	Air outlet	3)	Motor
2)	Power Connection (Cable: Black-White 230Vac 50Hz.)	4)	Mouth air inlet

# MOUNTING

DIMENSIONS (mm), MOUNTING HOLES AND CONNECTIONS TTG240

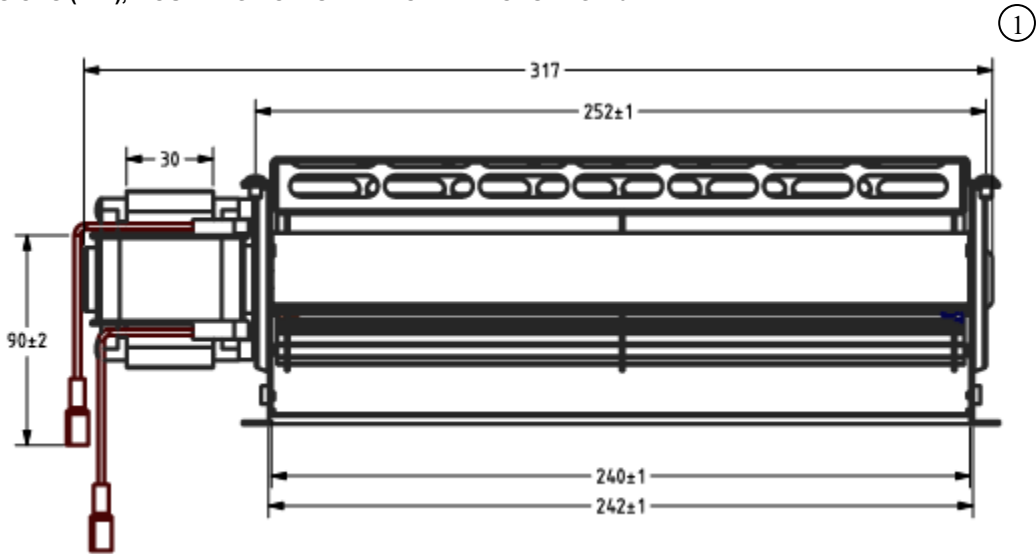

1MN0070 Rev 4

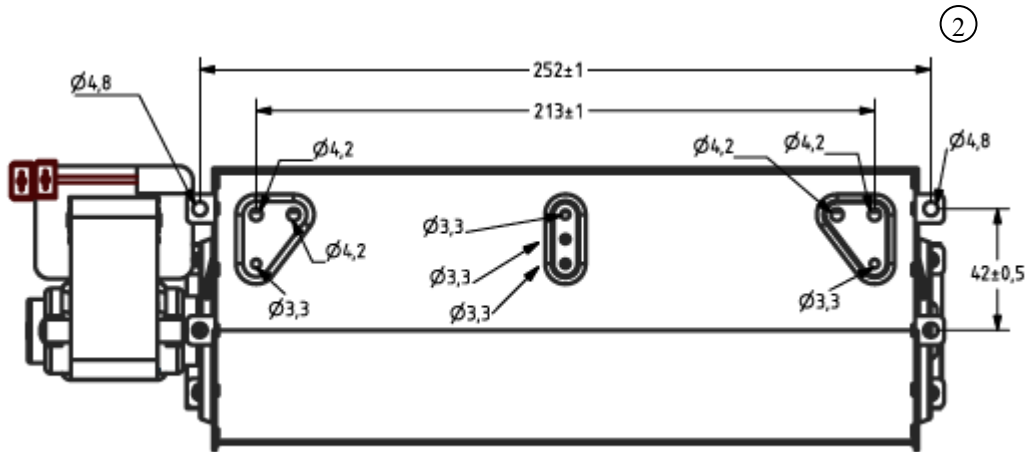

1MN0070 Rev 4

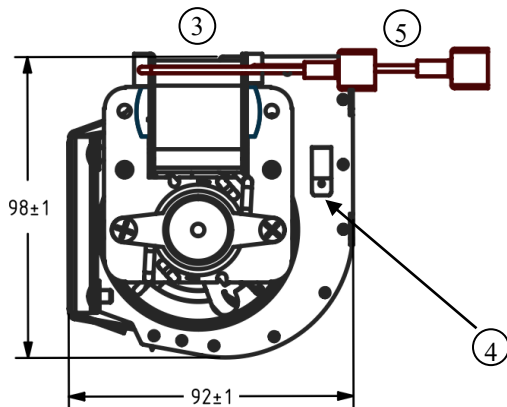

1)	Front view
2)	Rear view with mounting holes
3)	Motor side view
4)	Connecting grounding (Yellow-green) 
5)	Power Connection (Cable: Black-White 230Vac 50Hz.)

1MN0070 Rev 4

**DIMENSIONS (mm), MOUNTING HOLES AND CONNECTIONS TTG300**

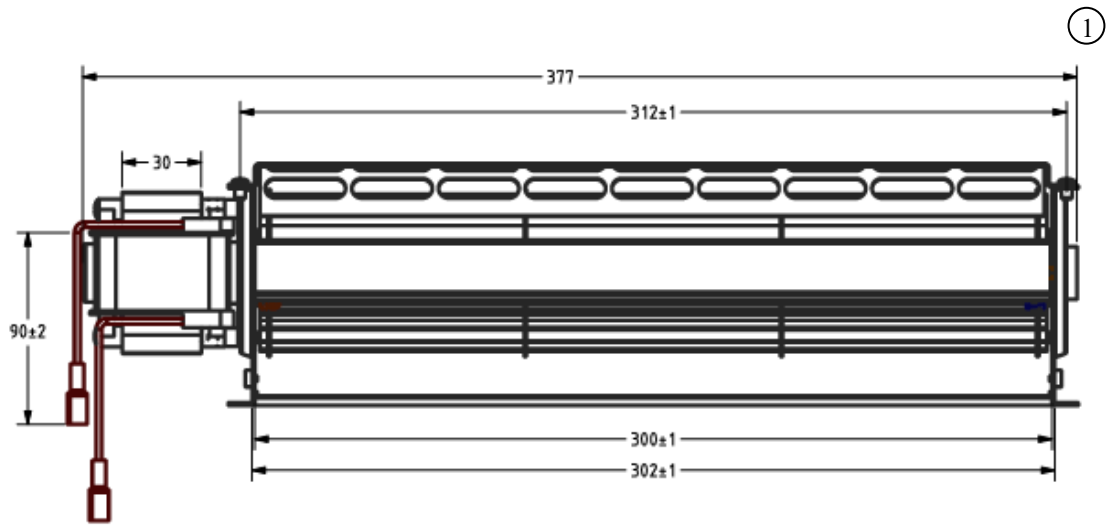

1MN0071 Rev. 4

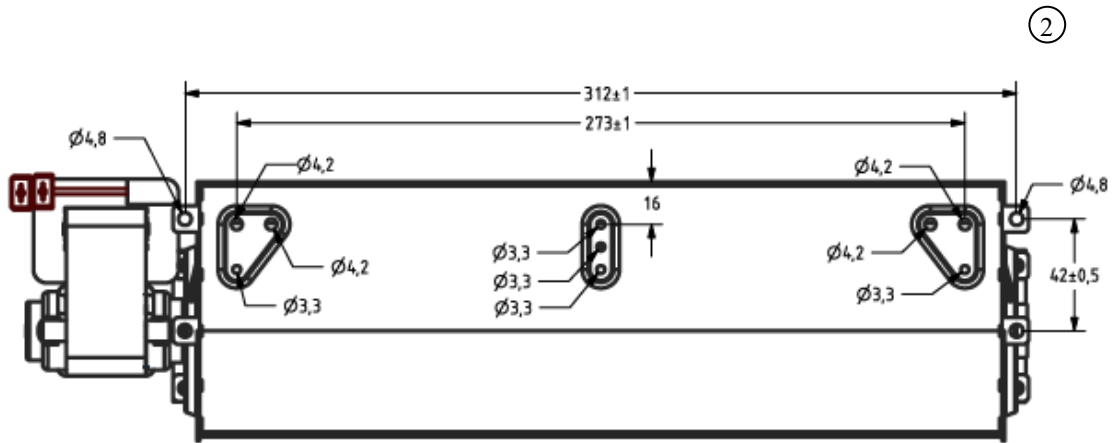

1MN0071 Rev. 4

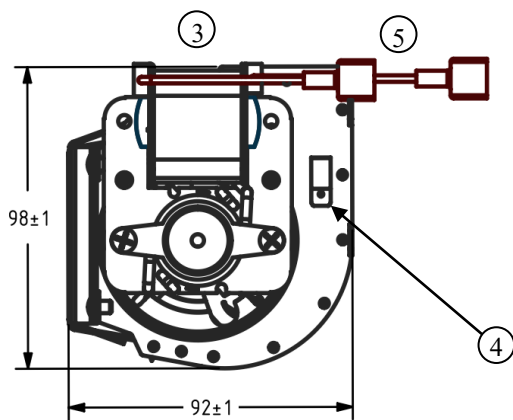

1MN0071 Rev. 4

1)	Front view
2)	Rear view with mounting holes
3)	Motor side view
4)	Connecting grounding (Yellow-green) 
5)	Power Connection (Cable: Black-White 230Vac 50Hz.)

DIMENSIONS (mm), MOUNTING HOLES AND CONNECTIONS TTG360

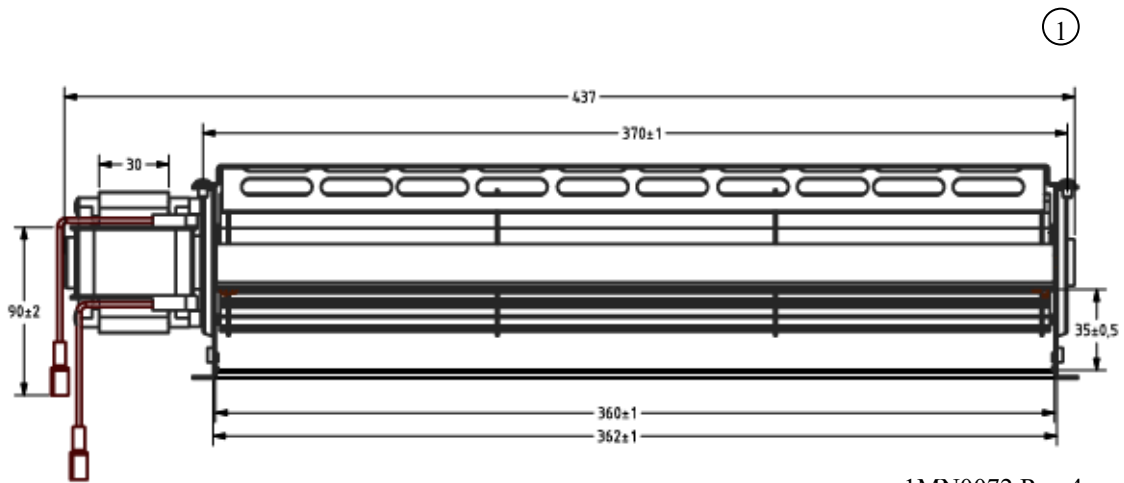

1MN0072 Rev.4

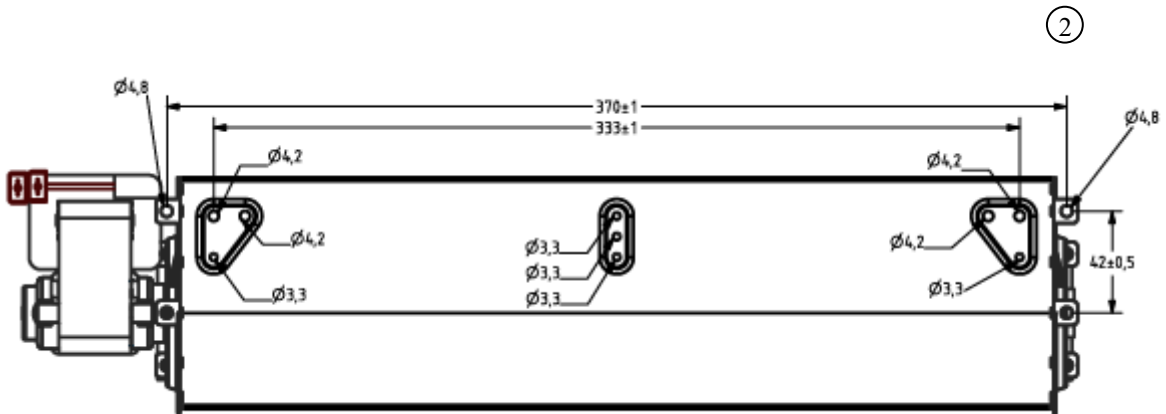

1MN0072 Rev.4

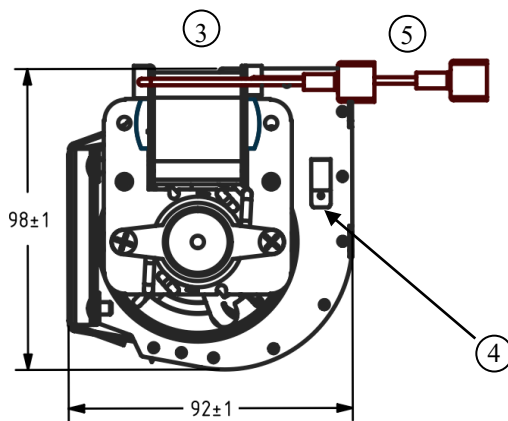

1MN0072 Rev.4

1)	Front view
2)	Rear view with mounting holes
3)	Motor side view
4)	Connecting grounding (Yellow-green) 
5)	Power Connection (Cable: Black-White 230Vac 50Hz.)

## MOUNTING NOTES

Fix the fans using the holes on the back, do not change the mounting holes of the fan. During the handling of the fans avoid deforming the fins of the impeller. Never change the motor positioning.

If the fan is mounted on board of a transformer the working position of the fan must comply with the safety distance, indicated in the manual of the transformer, on which you are installing the fan. The fan must be positioned in the horizontal plane, always make sure, through the help of a level, that the fan is positioned correctly.

The maximum rate of vibration permitted is 60Hz.



### ATTENTION:

Use the fan trying not obstruct the mouth of the inlet / outlet, whether partial or total occlusion of the air vents can.

### POWER SUPPLY

The value of power supply is indicated on the fan label, to see the available fan options see parameters at page 4.

Note: do not power the fan with different values of voltage and frequency. Always control those indicated on the label.

Maximum permitted harmonic content in accordance with EN 61000-3-2:

5%	3rd,
6%	5th,
5%	7th,
1.5%	9th,
3.5%	11th,
3%	13th,
0.3%	15th,

### ENVIRONMENTAL CONDITIONS OF USE

Absence of fine particles.

Absence of corrosive or flammable gases.

Relative humidity: 90% non-condensing (for short periods).

N.B.: maximum temperature as prescribed by IEC 60076-11.

It is not recommended to install the fans in marine environment, if not after treatment of metal parts.

**NOTE:** wrong installation and critical environmental conditions as: long periods of inactivity, high temperature high humidity, excessive dust and excessive vibration can anticipate the deterioration of the mechanical parts of the fans.

### MAINTENANCE

*In order to maintain the efficiency of the fans, we suggest to perform regularly, every 6 months, a cleaning operation of the fans (do it using only compressed air). Do not use oils or fats of any kind.*

*Any prolonged shutdown of the fan may be the cause of failure. The installation of the fans combined with thermometric Tecsystem avoids any longer standstill. Enabling the HFN Tecsystem present in the unit can be programmed cycles of activation of fans from 1 to 200 hours, recommended setting every 24 hours (for more information about the HFN check the manual of the unit).*

*When the fans are connected with Tecsystem VRT control unit always remember that reporting a defect by the VRT could be related to the malfunction of the fan. Do not reprogram the VRT without having carried out a verification of the status of the fans and a possible maintenance (cleaning fans with compressed air).*

**NOTE:** periodic maintenance and activation of the HFN function will allow you to extend the efficiency of the fans. The maintenance on the fans must be programmed as a function of environmental conditions in which they operate.

TROUBLE SHOOTING	CAUSES AND REMEDIES
The fan is powered, but the impeller does not turn.	Remove the power supply and check that: the power connectors are properly inserted into their home, the connection wires are tight, there are no obvious signs of burns on the connectors.
The fan runs very slow or too fast.	Check the value of the power, using a multimeter, and check the correspondence of the values with those reported on the identification label of the product purchased.
The impeller is stuck and cause the fan failure.	The critical environmental conditions can anticipate the deterioration of the mechanical parts. Proper planning of cleaning, maintenance and the installation of the VRT control series will allow you to lengthen significantly the efficiency of the fan.
If the problem persists, contact the TECSYSTEM technical department.	

## WARRANTY CONDITIONS

The Product purchased is covered by the manufacturer's or seller's warranty at the terms and conditions set forth in the "Tecsystem s.r.l.'s General Conditions of Sale", available at [www.tecsystem.it](http://www.tecsystem.it) and / or in the purchase agreement.

The warranty is considered valid only when the product is damaged by causes attributable to TECSYSTEM srl, such as manufacturing or components defects.

The warranty is invalid if the Product proves to have been tampered with / modified, incorrectly connected, because of voltages outside the limits, non-compliance with the assembly and use technical data, as described in this instruction manual.

The warranty is always ex Corsico as stated in the "General Conditions of Sale".

## EQUIPMENT DISPOSAL

European directive 2012/19/EU (WEEE) has been approved to reduce electrical and electronic waste and promote the recycling and reuse of the materials and components of said equipment, cutting down on the disposal of the residues and harmful components of electrical and electronic materials.



All the electrical and electronic equipment supplied after 13 August 2005 is marked with this symbol, pursuant to European directive 2012/19/EU on electrical and electronic waste (WEEE). Any electrical or electronic equipment marked with this symbol must be disposed of separately from normal domestic waste.

Returning used electrical devices: contact TECSYSTEM or your TECSYSTEM agent for information on the correct disposal of the devices.

TECSYSTEM is aware of the impact its products have on the environment and asks its customers active support in the correct and environmentally-friendly disposal of its devices.

## USEFUL CONTACTS

TECHNICAL INFORMATION: [ufficiotecnico@tecsystem.it](mailto:ufficiotecnico@tecsystem.it)

COMMERCIAL INFORMATION: [info@tecsystem.it](mailto:info@tecsystem.it)

