

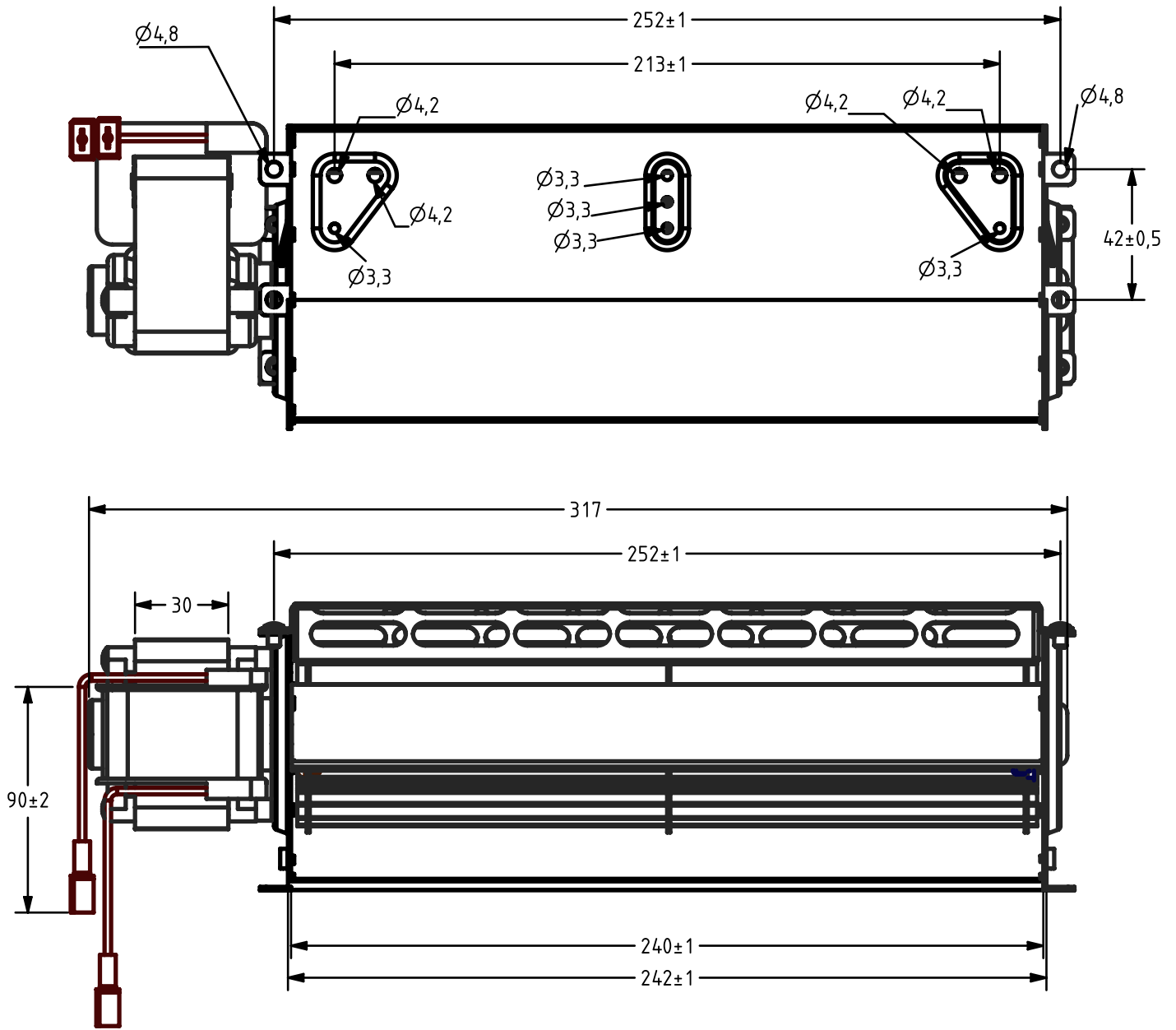
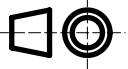

VISTA GENERALE
SCALA 1:2
GENERAL VIEW
SCALE 1:2



DESCRIZIONE / DESCRIPTION	N°
RETINA DI PROTEZIONE / PROTECTION GRID	1
GOMMINO IN SILICONE CON CUSCINETTO A SFERA / SILICONIC RUBBER PART WITH BALL BEARING	2
VENTOLA 60 L= 240 mm IN ALLUMINIO / 60 LENGTH 240 mm ALLUMINIUM FAN BLADE	3
COCCLEA IN LAMIERA PREZINCATA / PRE-GALVANIZED HOUSING	4
PROTEZIONE TERMICA / THERMAL PROTECTION	5
CAVI L= 90 mm CON FASTON MASCHIO 6,3 x 0,8 PREISOLATO / CABLES LENGTH 90 mm WITH MALE FASTON 6,3 x 0,8 PRE-INSULATED	6
MOTORE CON CUSCINETTI A SFERE / MOTOR WITH SELF-ALIGNING BALL BEARINGS	7

	DESCRIZIONE/DESCRIPTION: VENTILATORE TTG240 230V 50HZ	DATA/DATE: 27/02/2025	DIMENSIONI/DIMENSIONS: mm
	CODICE/CODE: 1VN0028	FOGLIO/SHEET: A3	SCALA/SCALE: 1:2
DISEGNATORE/DESIGNER: M.MATIUSI	NOTE:	REV: 4	
CONTROLLATO/CONTROLLED: A.PIETRASANTA	NORMATIVA/REGULATIONS: EN 22768/1-2 m-k	PROPRIETA' DI TECSYSTEM s.r.l VIETATA LA RIPRODUZIONE NON AUTORIZZATA PROPERTY OF TECSYSTEM s.r.l UNAUTHORIZED REPRODUCTION FORBIDDEN	
APPROVATO/APPROVED: S.COLOMBI	MATERIALE/MATERIAL:		